



CD Receiver with Advanced Bluetooth

CDA-137EBT

EN



- OWNER'S MANUAL
Please read before using this equipment.

ALPINE ELECTRONICS MARKETING, INC.
1-7, Yukigaya-Otsukamachi,
Ota-ku, Tokyo 145-0067, JAPAN
Phone: 03-5499-4531

ALPINE ELECTRONICS OF AMERICA, INC.
19145 Gramercy Place, Torrance,
California 90501, U.S.A.
Phone 1-800-ALPINE-1 (1-800-257-4631)

ALPINE ELECTRONICS OF CANADA, INC.
777 Supertest Road, Toronto,
Ontario M3J 2M9, Canada
Phone 1-800-ALPINE-1 (1-800-257-4631)

ALPINE ELECTRONICS OF AUSTRALIA PTY. LTD.
161-165 Princes Highway, Hallam
Victoria 3803, Australia
Phone 03-8787-1200

ALPINE ELECTRONICS GmbH
Wilhelm-Wagenfeld-Str. 1-3, 80807 München, Germany
Phone 089-32 42 640

ALPINE ELECTRONICS OF U.K. LTD.
Alpine House
Fletchamstead Highway, Coventry CV4 9TW, U.K.
Phone 0870-33 33 763

ALPINE ELECTRONICS FRANCE S.A.R.L.
(RCS PONTOISE B 338 101 280)
98, Rue de la Belle Etoile, Z.I. Paris Nord II,
B.P. 50016, 95945 Roissy Charles de Gaulle
Cedex, France
Phone 01-48638989

ALPINE ITALIA S.p.A.
Viale C. Colombo 8, 20090 Trezzano
Sul Naviglio (MI), Italy
Phone 02-484781

ALPINE ELECTRONICS DE ESPAÑA, S.A.
Portal de Gamarra 36, Pabellón, 32
01013 Vitoria (Alava)-APDO 133, Spain
Phone 945-283588

ALPINE ELECTRONICS (BENELUX) GmbH
Leuvensesteenweg 510-B6,
1930 Zaventem, Belgium
Phone 02-725-13 15

Operating Instructions

WARNING

WARNING.....	4
CAUTION.....	4
PRECAUTIONS.....	4

Getting Started

Accessory List.....	7
Turning Power On and Off.....	7
Source Selection.....	7
Detaching and Attaching the Front Panel.....	7
Detaching.....	7
Attaching.....	7
Initial System Start-Up.....	7
Adjusting Volume	8
Setting Time and Calendar.....	8

Radio

Listening to Radio.....	8
Presetting Stations Manually.....	8
Presetting Stations Automatically.....	9
Tuning to Preset Stations.....	9
Frequency Search Function.....	9

CD/MP3/WMA/AAC

Playback	9
Repeat Play.....	10
M.I.X. (Random Play).....	10
Searching for CD Text.....	10
Folder/File Name Search (concerning MP3/WMA/AAC).....	10
Folder Name Search mode.....	10
File Name Search mode.....	10
Search Position Memory.....	10
About MP3/WMA/AAC.....	11
Terminology.....	12

Sound Setting

Adjusting Subwoofer Level/Balance (Between Left and Right)/Fader (Between Front and Rear)/Auto Volume/Black Out/Defeat.....	12
Setting the MX Mode.....	13
Sound Setting.....	13
Adjusting the High Pass Filter.....	13
Turning Subwoofer ON/OFF.....	13

Setting the Subwoofer System.....	14
Setting the Subwoofer Phase.....	14
Setting the Subwoofer Channel (SUBW. Channel).....	14
Setting EQ mode.....	14
Setting the Time Correction Unit (TCR Parameter).....	14
Sound Field Adjustment.....	14
Adjusting the Parametric Equalizer Curve.....	14
Adjusting the Graphic Equalizer Curve.....	14
Adjusting the Time Correction.....	15
Storing the Sound Field Adjustment Settings.....	15
Recalling the Stored Sound Field Adjustment Settings.....	15

Other Functions

Displaying the Text.....	16
About the indication display.....	17
About "Text".....	17
Displaying Time.....	17

SETUP

Setting	17
General Setting	18
Birthday Opening Message Setting (Birthday Set).....	18
Setting the Clock Display (Clock Mode).....	18
Setting of Calendar Display Pattern Switching (Calendar).....	18
Playing MP3/WMA/AAC Data (Play Mode)...	18
Sound (Beep) Guide Function.....	18
Setting the External Digital Input.....	18
Setting the AUX Mode (V-Link).....	18
Connecting to an External Amplifier.....	19
Demonstration.....	19
Display Setting.....	19
Changing Lighting Colour.....	19
Dimmer Control.....	19
Dimmer Level Setting.....	19
Scroll Type Setting.....	20
Scroll Setting (Text Scroll).....	20
Switching the Character Font.....	20
Switching the Animation Display Type (BGV Select).....	20
Opening Message ON/OFF Setting.....	20
Tuner Setting.....	20
Setting the TUNER (FM) tone quality.....	20
USB Setting.....	20
Setting the USB Search Mode.....	20
Setting the USB Skip function.....	20

BT Hands Free Calling

Setup Before Using.....	21
About BLUETOOTH.....	21
Before Using BLUETOOTH Function.....	21
How to connect to a BLUETOOTH compatible device (Pairing).....	21
Pairing a BLUETOOTH compatible device with SSP (Secure Simple Pairing).....	21
Pairing a BLUETOOTH compatible device without SSP (Secure Simple Pairing).....	21
BLUETOOTH SETUP.....	21
Setting the BLUETOOTH Connection (BT IN).....	22
Hands-Free Phone setting (HFP).....	22
BLUETOOTH Audio setting (Audio).....	22
Setting the BLUETOOTH Device.....	22
Setting the Visible Mode.....	22
Pairing a BLUETOOTH Device from the unit.....	22
Setting the BLUETOOTH sound quality.....	23
Adjusting the volume (VOL LV Adj).....	23
Sound Type setting (Type Set).....	23
Setting the caller information display/text message indicator ON/OFF.....	23
Setting text message indicator ON/OFF (Short Message).....	23
Setting the caller information display ON/OFF (Telephone).....	23
Phone Book Auto Update ON/OFF.....	23
Changing the Phone book List Order.....	23
Setting the Received Calls automatically (Auto Answer).....	24
Displaying the phone service provider name.....	24
Selecting the output speaker.....	24
Displaying the firmware version.....	24
Updating the firmware.....	24
Hands-Free Phone Control.....	24
About the Hands-Free Phone.....	24
Answering a Call.....	24
Hanging up the Telephone.....	24
Calling.....	25
Voice Dial Operation.....	25
Redialing a Number In Outgoing History.....	25
Dialing a Number In Incoming History.....	25
Dialing a Number In Incoming Missed Call History.....	25
Dialing a Number In The Phone Book.....	25
Phone book Alphabet Search Function.....	26
Call waiting function.....	26
Preset a number in the Phone Menu (Shortcut dial).....	26

Dialing the preset number.....	26
Adjusting the volume when receiving a Call.....	26
Muting the microphone input quickly (Voice Mute).....	26
Call Switching Operation.....	27
BLUETOOTH Audio Operation.....	27
Recalling the BLUETOOTH Audio Mode.....	27
Selecting the desired Song.....	27
Pausing.....	27

USB Memory (optional)

Connecting the USB Memory (optional).....	27
Using the USB Memory Banking Function.....	27
About MP3/WMA/AAC File of USB Memory.....	28
Repeat Play.....	28
M.I.X. (Random Play).....	28
Searching for a desired Song.....	28
Searching by Tag information.....	28
Searching by (FILE NAME) mode.....	29
Direct Search Function.....	29
Select Playlist/Artist/Album/Genre/Composer/Folder.....	30
Alphabet search function.....	30
Search Position Memory.....	30

iPod/iPhone (optional)

Connecting an iPod/iPhone.....	30
Playback.....	31
Searching for a desired Song.....	31
Direct Search Function.....	31
Select Playlist/Artist/Album/Genre/Composer/Episode.....	32
Alphabet search function.....	32
Search Position Memory.....	32
Random Play Shuffle (M.I.X.).....	32
Repeat Play.....	32
Displaying the Text.....	33

IMPRINT Operation (optional)

Changing MultEQ mode.....	33
Adjusting Subwoofer Level/Bass Level/Treble Level/Fader (Between Front and Rear)/BalanceBalance (Between Left and Right)/Black Out in MultEQ mode.....	34
Adjusting Sound Setting in Manual Mode.....	34
Turning Subwoofer ON/OFF.....	34
Setting the Subwoofer System.....	34
Setting the Subwoofer Phase.....	35

Setting the Subwoofer Channel (SUBW. Channel).....	35
Equalizer Presets (Factory's EQ).....	35
Setting the Response Slope for the High Range Speaker (TW Setup).....	35
Setting the Filter type.....	35
Turning Media Xpander ON/OFF.....	35
Setting the MX Level.....	35
Setting EQ mode.....	36
Setting the Time Correction Unit (TCR Parameter).....	36
Sound Field Adjustment.....	36
Adjusting the Parametric Equalizer Curve.....	36
Adjusting the Graphic Equalizer Curve.....	36
Adjusting the Time Correction.....	36
Adjusting the Crossover Settings.....	36
Storing the Sound Field Adjustment Settings.....	37
Recalling the Stored Sound Field Adjustment Settings.....	37
About Time Correction.....	38
Example 1: Front Left Seat.....	38
Example 2: All Seats.....	38
About the Crossover.....	39

Changer (optional)

Controlling CD Changer (optional).....	40
Playing MP3 Files with the CD Changer (optional).....	41
Multi-Changer Selection (optional).....	41

Remote Control

Controls on Remote Control.....	41
Operating the Audio Processor.....	42
Battery Replacement.....	42
Controllable With Remote Control.....	42
Connectable to Remote Control Interface Box.....	43

Information

In Case of Difficulty.....	43
Basic.....	43
Radio.....	43
CD.....	43
MP3/WMA/AAC.....	44
Audio.....	44
iPod.....	44
Indication for CD Player.....	44
Indication for CD Changer.....	44
Indication for USB Memory.....	45
Indication for iPod Mode.....	45
BLUETOOTH mode.....	45
Specifications.....	46

Installation and Connections

WARNING	47
CAUTION	47
PRECAUTIONS	47
Installation.....	48
Removal.....	48
iPod/iPhone Connection (sold separately).....	48
Remove the iPod/iPhone.....	49
USB Memory Connection (sold separately).....	49
Connect USB Memory.....	49
Remove USB Memory.....	49
Mounting the Microphone.....	49
Connections.....	50

Operating Instructions

WARNING

WARNING

This symbol means important instructions. Failure to heed them can result in serious injury or death.

DO NOT OPERATE ANY FUNCTION THAT TAKES YOUR ATTENTION AWAY FROM SAFELY DRIVING YOUR VEHICLE.

Any function that requires your prolonged attention should only be performed after coming to a complete stop. Always stop the vehicle in a safe location before performing these functions. Failure to do so may result in an accident.

KEEP THE VOLUME AT A LEVEL WHERE YOU CAN STILL HEAR OUTSIDE NOISES WHILE DRIVING.

Excessive volume levels that obscure sounds such as emergency vehicle sirens or road warning signals (train crossings, etc.) can be dangerous and may result in an accident. LISTENING AT LOUD VOLUME LEVELS IN A CAR MAY ALSO CAUSE HEARING DAMAGE.

DO NOT DISASSEMBLE OR ALTER.

Doing so may result in an accident, fire or electric shock.

USE ONLY IN CARS WITH A 12 VOLT NEGATIVE GROUND.

(Check with your dealer if you are not sure.) Failure to do so may result in fire, etc.

KEEP SMALL OBJECTS SUCH AS BATTERIES OUT OF THE REACH OF CHILDREN.

Swallowing them may result in serious injury. If swallowed, consult a physician immediately.

USE THE CORRECT AMPERE RATING WHEN REPLACING FUSES.

Failure to do so may result in fire or electric shock.

DO NOT BLOCK VENTS OR RADIATOR PANELS.

Doing so may cause heat to build up inside and may result in fire.

USE THIS PRODUCT FOR MOBILE 12V APPLICATIONS.

Use for other than its designed application may result in fire, electric shock or other injury.

DO NOT PLACE HANDS, FINGERS OR FOREIGN OBJECTS IN INSERTION SLOTS OR GAPS.

Doing so may result in personal injury or damage to the product.

CAUTION

This symbol means important instructions. Failure to heed them can result in injury or material property damage.

HALT USE IMMEDIATELY IF A PROBLEM APPEARS.

Failure to do so may cause personal injury or damage to the product. Return it to your authorized Alpine dealer or the nearest Alpine Service Centre for repairing.

DO NOT MIX NEW BATTERIES WITH OLD BATTERIES. INSERT WITH THE CORRECT BATTERY POLARITY. .

When inserting the batteries, be sure to observe proper polarity (+ and -) as instructed. Rupture or chemical leakage from the battery may cause fire or personal injury.

PRECAUTIONS

Product Cleaning

Use a soft dry cloth for periodic cleaning of the product. For more severe stains, please dampen the cloth with water only. Anything else has the chance of dissolving the paint or damaging the plastic.

Temperature

Be sure the temperature inside the vehicle is between +60°C (+140°F) and -10°C (+14°F) before turning your unit on.

Moisture Condensation

You may notice the CD playback sound wavering due to condensation. If this happens, remove the disc from the player and wait about an hour for the moisture to evaporate.

Damaged Disc

Do not attempt to play cracked, warped, or damaged discs. Playing a bad disc could severely damage the playback mechanism.

Maintenance

If you have problems, do not attempt to repair the unit yourself. Return it to your Alpine dealer or the nearest Alpine Service Station for servicing.

Never Attempt the Following

Do not grip or pull out the disc while it is being pulled back into the player by the automatic reloading mechanism.

Do not attempt to insert a disc into the unit when the unit power is off.

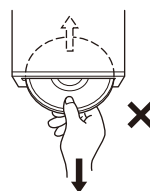

Inserting Discs

Your player accepts only one disc at a time for playback. Do not attempt to load more than one disc.

Make sure the label side is facing up when you insert the disc. "Error" will be displayed on your player if you insert a disc incorrectly. If "Error" continues to be displayed even though the disc has been inserted correctly, push the **RESET** button with a pointed object such as a ballpoint pen.

Playing a disc while driving on a very bumpy road may result in skips, but this will not scratch the disc or damage the player.

New Discs

To prevent the CD from jamming, "Error" is displayed if discs with irregular surfaces are inserted or if discs are inserted incorrectly. When a new disc is ejected immediately after initial loading, use your finger to feel around the inside of the centre hole and outside edge of the disc. If you feel any small bumps or irregularities, this could inhibit proper loading of the disc. To remove the bumps, rub the inside edge of the hole and outside edge of the disc with a ballpoint pen or other such instrument, then insert the disc again.

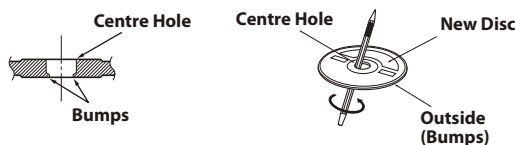

Irregular Shaped Discs

Be sure to use round shape discs only for this unit and never use any special shape discs.

Use of special shape discs may cause damage to the mechanism.



Installation Location

Make sure this unit will not be installed in a location subjected to:

- Direct sun and heat
- High humidity and water
- Excessive dust
- Excessive vibrations

Correct Handling

Do not drop the disc while handling. Hold the disc so you will not leave fingerprints on the surface. Do not affix tape, paper, or gummed labels to the disc. Do not write on the disc.

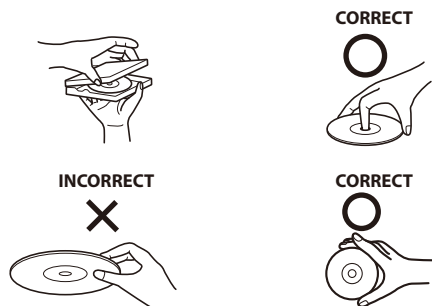

Disc Cleaning

Fingerprints, dust, or soil on the surface of the disc could cause the CD player to skip. For routine cleaning, wipe the playing surface with a clean, soft cloth from the centre of the disc to the outer edge. If the surface is heavily soiled, dampen a clean, soft cloth in a solution of mild neutral detergent before cleaning the disc.



Disc Accessories

There are various accessories available on the market for protecting the disc surface and improving sound quality. However, most of them will influence the thickness and/or diameter of the disc. Using such accessories can cause the disc to be out of standard specifications and may create operational problems. We recommend not using these accessories on discs played in Alpine CD players.

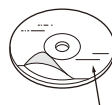

Transparent Sheet

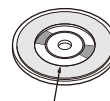

Disc Stabilizer

On handling Compact Discs (CD/CD-R/CD-RW)

- Do not touch the surface.
- Do not expose the disc to direct sunlight.
- Do not affix stickers or labels.
- Clean the disc when it is dusty.
- Make sure that there are no bumps around the disc.
- Do not use commercially available disc accessories.

Do not leave the disc in the car or the unit for a long time. Never expose the disc to direct sunlight. Heat and humidity may damage the CD and you may not be able to play it again.

To customers using CD-R/CD-RW

- If a CD-R/CD-RW cannot be played back, make sure the last recording session was closed (finalized).
- Finalize the CD-R/CD-RW if necessary, and attempt playback again.

About media that can be played

Use only compact discs with the label side showing the CD logo marks below.



If you use unspecified compact discs, correct performance cannot be guaranteed.

You can play CD-Rs (CD-Recordables)/CD-RWs (CD-ReWritables) which have been recorded only on audio devices. You can also play CD-Rs/CD-RWs containing MP3/WMA formatted audio files.

- Some of the following CDs may not play on this unit: Flawed CDs, CDs with fingerprints, CDs exposed to extreme temperatures or sunlight (e.g. left in the car or this unit), CDs recorded under unstable conditions, CDs on which a recording failed or a re-recording was attempted, copy-protected CDs which do not conform to the audio CD industry standard.
- Use discs with MP3/WMA/AAC files written in a format compatible with this unit. For details, refer to "About MP3/WMA/AAC" on page 11.
- ROM data other than audio files contained in a disc will not produce sound when played back.

Protecting the USB Connection Terminal

- Only a USB Memory or iPod/iPhone can be connected to the USB connector on this unit. Correct performance using other USB products cannot be guaranteed.
- If the USB connector is used, be sure to use a USB extension cable (supplied). A USB hub is not supported.
- Depending on the connected USB Memory device, the unit may not function or some functions may not be performed.
- The audio file format that can be played back on the unit is MP3/WMA/AAC.
- Artist/song name, etc. can be displayed, however characters may not be correctly displayed.

On Handling USB Memory

CAUTION

Alpine accepts no responsibility for lost data, etc., even if data, etc., is lost while using this product.

- To prevent malfunction or damage, note the following points. Read the USB Memory Owner's Manual thoroughly. Do not touch the terminals by hand or metal. Do not subject USB Memory to excessive shock. Do not bend, drop, disassemble, modify or soak in the water.
- Avoid usage or storage in the following locations: Anywhere in the car exposed to direct sunlight or high temperatures. Anywhere the possibility of high humidity or corrosive substances is present.
- Fix the USB Memory in a location where driver operation will not be hindered.
- USB Memory may not function correctly at high or low temperature.
- The USB Flash Memory supports only 512 or 2,048 bytes per sector.
- Use only certified USB Memory. Note that even certified USB Memory, may not function correctly depending on its type or state.
- USB Memory function is not guaranteed. Use USB Memory according to the terms of agreement.
- Depending on the settings of the USB Memory type, memory state or encoding software, the unit may not play back or display properly.
- A file that is copy-protected (copyright protection) cannot be played back.
- USB Memory may take time to start playback. If there is a particular file other than audio in the USB Memory, it may take considerable time before the file is played back or searched.
- The unit can play back "mp3" or "wma" file extension.
- Do not add the above extension to a file other than audio data. This non-audio data will not be recognized. The resulting playback may contain noise that can damage speakers and/or amplifiers.
- It is recommended to back up important data on a personal computer.
- Do not remove the USB device while playback is in progress. Change SOURCE to something other than USB, and then remove the USB device to prevent possible damage to its memory.

- *iPhone, iPod, iPod classic, iPod nano, and iPod touch are trademarks of Apple Inc., registered in the U.S. and other countries.*
- *"Made for iPod," and "Made for iPhone," mean that an electronic accessory has been designed to connect specifically to iPod, or iPhone, respectively, and has been certified by the developer to meet Apple performance standards. Apple is not responsible for the operation of this device or its compliance with safety and regulatory standards. Please note that the use of this accessory with iPod, or iPhone may affect wireless performance.*
- *The BLUETOOTH® word mark and logos are registered trademarks owned by the Bluetooth SIG, Inc. and any use of such marks by Alpine Electronics, Inc. is under license.*
- *Windows Media, and the Windows logo are trademarks, or registered trademarks of Microsoft Corporation in the United States and/or other countries.*
- *© 2010 Nokia. All rights reserved. Nokia and Works with Nokia are trademarks or registered trademarks of Nokia Corporation.*
- *"MPEG Layer-3 audio coding technology licensed from Fraunhofer IIS and Thomson."*
- *"Supply of this product only conveys a license for private, non-commercial use and does not convey a license nor imply any right to use this product in any commercial (i.e. revenue-generation) real time broadcasting (terrestrial, satellite, cable and/or any other media), broadcasting/streaming via internet, intranets and/or other networks or in other electronic content distribution systems, such as pay-audio or audio-on-demand applications. An independent licence for such use is required. For details, please visit <http://www.mp3licensing.com>"*

Getting Started

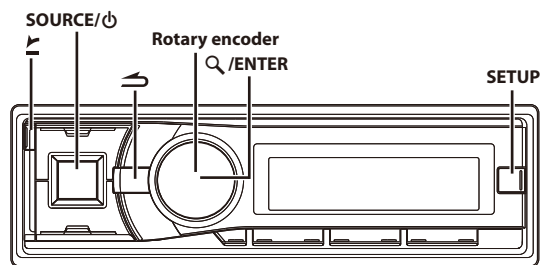

Accessory List

• Head unit	1
• Power cable.....	1
• USB Cable.....	1
• Interface cable for iPod.....	1
• Microphone.....	1
• Mounting sleeve.....	1
• Carrying case	1
• Bracket key	2
• Screw (M5 × 8)	4
• Remote Control	1
• Battery (AAA size).....	2
• Owner's Manual.....	1 set

Turning Power On and Off

Press SOURCE/⏻ to turn on the unit.

Note

- The unit can be turned on by pressing any other button except ⏻.

Press and hold SOURCE/⏻ for at least 2 seconds to turn off the unit.

Note

- The first time power is turned on, the volume will start from level 12.

Source Selection

Press SOURCE/⏻ to change the source.

TUNER → DISC → USB/USB iPod*1 → Bluetooth Audio*2 →
CHANGER*3 → AUXILIARY*4 → TUNER

- *1 Displayed only when the iPod/iPhone is connected.
- *2 Displayed only when Bluetooth Audio is set to ON, refer to "Setting the BLUETOOTH Connection (BT IN)" on page 22.
- *3 Only when the CD changer is connected.
- *4 Displayed only when the AUX IN is set to ON, refer to "Setting the AUX Mode (V-Link)" on page 18.

Detaching and Attaching the Front Pane

Detaching

- 1 Turn off the unit power.

- 2 Press (OPEN) to open the front panel (figure 1).

To close the front panel, press the left side until it locks as shown in the figure 2.

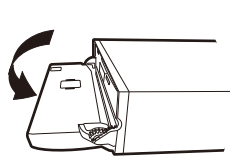

figure 1

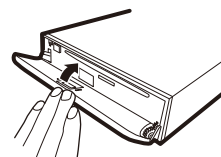
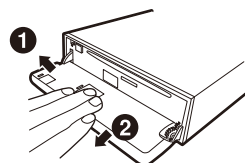

figure 2

- 3 Grasp the front panel firmly, slide to the left and then pull to remove.



Note

- The front panel may become hot in normal usage (especially the connector terminals on the back of the front panel). This is not a malfunction.
- To protect the front panel, place it in the supplied carrying case.
- When detaching the front panel, do not apply excessive force as it may result in malfunction.
- Do not leave the front panel open, or drive the car with the panel open as it may result in an accident or malfunction.

Attaching

- 1 Insert the right side of the front panel into the main unit. Align the groove on the front panel with the projections on the main unit.
- 2 Push the left side of the front panel until it locks firmly into the main unit.

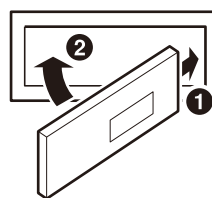

Note

- Before attaching the front panel, make sure that there is no dirt or dust on the connector terminals and no foreign object between the front panel and the main unit.
- Attach the front panel carefully, holding the sides of the front panel to avoid pushing buttons by mistake.

Initial System Start-Up

Be sure to press the **RESET** switch when using the unit for the first time, after changing the car battery, etc.

- 1 Turn off the unit power.

- Press **OPEN** to open the front panel, and then remove it.
- Press **RESET** with a ballpoint pen or similar pointed object.

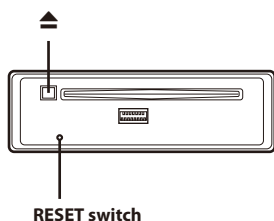

Adjusting Volume

Turn the **Rotary encoder** until the desired sound is obtained.

Setting the Time and Calendar

- Press and hold **SETUP** for at least 2 seconds to activate the **SETUP** selection mode.
- Turn the **Rotary encoder** to select **General**, and then press **Q/ENTER**.
Bluetooth ↔ General ↔ Display ↔ Tuner ↔ USB ↔ Bluetooth
- Turn the **Rotary encoder** to select **Clock Adjust**, and then press **Q/ENTER**.
- Turn the **Rotary encoder** to set year.
- Press **Q/ENTER**.
- Repeat steps 4 and 5 above to set month, date, hour and minute.
- Press and hold **SETUP** for at least 2 seconds to return to normal mode.

Note

- Pressing **BACK** returns to the previous **SETUP** mode.
- If no operation is performed for 60 seconds, **SETUP** is cancelled.
- To synchronize the clock to another clock/watch or radio time announcement, press and hold **Q/ENTER** for at least 2 seconds after setting the "hour". Minutes will reset to 00. If the display shows over "30" minutes when you do this, the time will advance one hour.

Radio

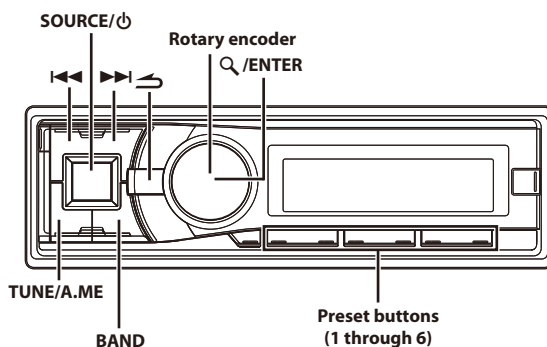

Listening to Radio

- Press **SOURCE/⏻** to select **TUNER** mode.
 - Press **BAND** repeatedly until the desired radio band is displayed.
F1 (FM1) → F2 (FM2) → AM → F1 (FM1)
 - Press **TUNE/A.ME** to select the tuning mode.
DX (Distance mode) → LOCAL (Local mode) → MANUAL (Manual mode) → DX (Distance mode)
- Note**
- The initial mode is Distance mode.
- Distance mode:**
Both strong and weak stations will be automatically tuned in (Automatic Seek Tuning).
- Local mode:**
Only strong stations will be automatically tuned in (Automatic Seek Tuning).
- Manual mode:**
The frequency is manually tuned in steps (Manual tuning).
- Press **◀◀** or **▶▶** to tune in the desired station.
Holding down **◀◀** or **▶▶** will change the frequency continuously.

Presetting Stations Manually

Tune in the station you want to store. Press and hold, for at least 2 seconds, any one of the **preset buttons (1 through 6)** into which you wish to store the station.

The display shows the band, preset number and station frequency memorized.

Note

- A total of 18 stations can be stored in the preset memory (6 stations for each band; FM1, FM2 and AM).
- If you store a station in a preset memory which already has a station, the current station will be cleared and replaced with the new station.

Presetting Stations Automatically

- 1 Press **BAND** repeatedly until the desired radio band is displayed.
- 2 Press and hold **TUNE/A.ME** for at least 2 seconds.

The frequency on the display continues to change while the automatic memory is in progress. The tuner will automatically seek and store 6 strong stations in the selected band. They will be stored into preset buttons 1 to 6 in order of signal strength. When the automatic memory has been completed, the tuner goes to the station stored in preset location No.1.

Note

- If no stations are stored, the tuner will return to the original station you were listening to before the auto memory procedure began.

Tuning to Preset Stations

Select the desired band, then press any one of the station preset buttons (1 through 6) that has your desired radio station in memory.

The display shows the band, preset number and frequency of the station selected.

Frequency Search Function

You can search for a radio station by its frequency.

- 1 Press **Q/ENTER** in Radio mode to activate Frequency search mode.
- 2 Turn the **Rotary encoder** to select the desired frequency.
- 3 Press **Q/ENTER** to receive the selected frequency.

Note

- Press **↶** in the search mode to cancel. Or, the search mode will be cancelled if no operation is performed for 10 seconds.

CD/MP3/WMA/AAC

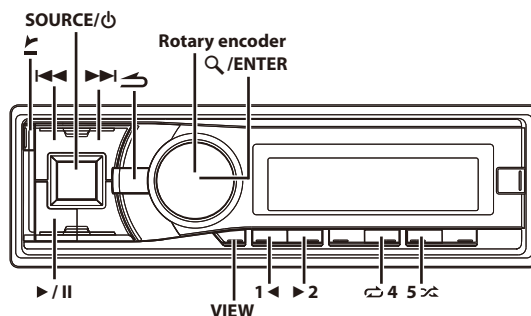

Playback

- 1 Press **⏻** (OPEN)
The front panel will open.
- 2 Insert a disc with the label side facing up.
The disc will be pulled into the unit automatically.

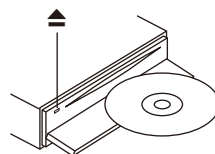

Note

- When a disc is already inserted, press **SOURCE/⏻** to switch to the DISC mode.
- 3 While playing back MP3/WMA/AAC, press **1◀** or **▶2** to select the desired folder.
Pressing and holding **1◀** or **▶2** will change folders continuously.
 - 4 Press **◀◀** or **▶▶** to select the desired track (file).
Pressing and holding **◀◀** or **▶▶** will fast backward/fast forward track continuously.
 - 5 To pause playback, press **▶/II**.
Pressing **▶/II** again will resume playback.
 - 6 After pressing **⏻** (OPEN) to open the front panel, press **⏻** to eject the disc.

Note

- Do not remove a CD during its eject cycle. Do not load more than one disc at a time. A malfunction may result from doing either.
- Three-inch (8 cm) CDs can not be used.
- Any file protected by DRM (Digital Rights Management) copy protection, cannot be played back on this unit.
- The track display for MP3/WMA/AAC data playback is the file numbers recorded on the disc.
- The playback time may not be correctly displayed when a VBR (Variable Bit Rate) recorded file is played back.
- Press **VIEW** to switch the display. For details, refer to "Displaying the Text" on page 16.

Repeat Play

1 Press 4

The song is played back repeatedly.

RPT*¹ → RPT  *² → RPT  *³ → (off) → RPT

*¹ Only a track/file is repeatedly played back.

*² Only files in a folder are repeatedly played back. (MP3/WMA/AAC mode only).

*³ A disc is repeatedly played back (When a CD changer is connected.).

Note

• If RPT is set to ON during M.I.X. play in CD changer mode, M.I.X. will apply to the current disc only.

2 To cancel repeat play, select (off) with the above procedure.

M.I.X. (Random Play)

1 Press 5

The songs are played back in random sequence.

MIX*¹ → MIX  *² → MIX  *³ → (off) → MIX

*¹ The tracks are played back in random sequence. (CD mode only)

*² Only files in a folder are played back in random sequence. (MP3/WMA/AAC mode only)

*³ For CD, the tracks on all the CDs in the current magazine will be included in the random playback sequence. (When a CD changer equipped with the ALL M.I.X. function is connected.); For MP3/WMA/AAC, files are played back in random sequence. If an MP3 compatible CD changer is connected, all files in a disc are played back in random sequence, and playback shifts to the next disc.

Note

• If M.I.X. is set to ON during RPT  (REPEAT ALL) play in CD changer mode, M.I.X. will apply to the current disc only.

2 To cancel M.I.X. play, select (off) with the above procedure.

Searching for CD Text

On discs utilizing CD Text, songs can be searched and played by using their recorded titles. For discs without CD Text, searches are made using the track numbers associated with each song.

1 Press /ENTER during play.

This will set the search mode.

2 Turn the Rotary encoder to select the desired track, and then press /ENTER.

This will play the selected track.



Note

- Press  in the search mode to cancel. Or, the search mode is cancelled if no operation is performed for 60 seconds.
- When CD Text Search is made during M.I.X. play, the M.I.X. play mode will be cancelled.
- In CD changer mode, searches can only be made using the track numbers associated with each song, even though discs utilize CD text.





Folder/File Name Search (Concerning MP3/WMA/AAC)

Folder and file names may be searched and displayed during playback.



Folder Name Search mode

- 1 During MP3/WMA/AAC playback, press  /ENTER to activate the search mode.
- 2 Turn the Rotary encoder to select Folder Name Search mode, and then press  /ENTER.
- 3 Turn the Rotary encoder to select the desired folder.
- 4 Press and hold  /ENTER for at least 2 seconds to play back the first file in the selected folder.



Note

- Press and hold  for at least 2 seconds in the search mode to cancel. Or, the search mode is cancelled if no operation is performed for 60 seconds.
- To search for files in the Folder Name Search mode, press  /ENTER. Files in the folder may be searched.
- Press  or  to select folders in which to search for a file.
- Press  to exit Folder Name Search mode in step 3 in order to select File Name Search mode.
- When Folder Name Search is made during M.I.X. play, the M.I.X. play mode will be cancelled.
- The root folder is displayed as “\ROOT”.

File Name Search mode

- 1 During MP3/WMA/AAC playback, press  /ENTER to activate the search mode.
- 2 Turn the Rotary encoder to select File Name Search mode, and then press  /ENTER.
- 3 Select the desired file by turning the Rotary encoder.
- 4 Press  /ENTER to play back the selected file.

Note

- Press and hold  for at least 2 seconds in the search mode to cancel. Or, the search mode is cancelled if no operation is performed for 60 seconds.
- Press  in the search mode to return to the previous mode.
- When File Name Search is made during M.I.X. play, the M.I.X. play mode will be cancelled.

Search Position Memory

During playback, you can quickly return to the last-selected hierarchy level in the search mode.

Press .

The hierarchy you selected last in the search mode is displayed.

About MP3/WMA/AAC

⚠ CAUTION

Except for private use, duplicating audio data (including MP3/WMA/AAC data) or distributing, transferring, or copying it, whether for free or for a fee, without permission of the copyright holder is strictly prohibited by the Copyright Act and by international treaty.

What is MP3?

MP3, whose official name is "MPEG Audio Layer 3," is a compression standard prescribed by the ISO, the International Standardization Organization and MPEG which is a joint activity institution of the IEC. MP3 files contain compressed audio data. MP3 encoding is capable of compressing audio data at extremely high ratios, reducing the size of music files to as much as one-tenth their original size. This is achieved while still maintaining near CD quality. The MP3 format realises such high compression ratios by eliminating the sounds that are either inaudible to the human ear or masked by other sounds.

What is WMA?

WMA, or "Windows Media™ Audio," is compressed audio data. WMA is similar to MP3 audio data.

What is AAC?

AAC is the abbreviation for "Advanced Audio Coding", and is a basic format of audio compression used by MPEG2 or MPEG4.

Method for creating MP3/WMA/AAC files

Audio data is compressed using software with MP3/WMA/AAC codecs. For details on creating MP3/WMA/AAC files, refer to the user's manual for that software.

MP3/WMA/AAC files that are playable on this device have the file extensions "mp3"/"wma"/"m4a". Files with no extension cannot be played back (WMA ver. 7, 8 and 9 are supported). Protected files are not supported, neither are raw AAC files (using the ".aac" extension). There are many different versions of the AAC format. Confirm that the software being used conforms to the acceptable formats listed above. It's possible that the format may be unplayable even though the extension is valid. Playback of AAC files encoded by iTunes is supported.

Supported playback sampling rates and bit rates

MP3

Sampling rates: 48 kHz, 44.1 kHz, 32 kHz, 24 kHz, 22.05 kHz, 16 kHz, 12 kHz, 11.025 kHz, 8 kHz

Bit rates: 8 - 320 kbps

WMA

Sampling rates: 48 kHz, 44.1 kHz, 32 kHz

Bit rates: 32 - 192 kbps

AAC

Sampling rates: 48 kHz, 44.1 kHz, 32 kHz, 24 kHz, 22.05 kHz, 16 kHz, 12 kHz, 11.025 kHz, 8 kHz

Bit rates 16 - 320 kbps

This device may not play back correctly depending on sampling rates. In the USB mode, the playback time may not be correctly displayed when a VBR (Variable Bit Rate) recorded file is played back.

ID3 tags/WMA tags

This device supports ID3 tag v1 and v2, and WMA/AAC tag. If tag data is in an MP3/WMA/AAC file, this device can display the title (track title), artist name, and album name ID3 tag/WMA/AAC tag data. This device can only display single-byte alphanumeric characters (up to 30 for ID3 tags and up to 15 for WMA tags) and the underscore. For non-supported characters, "No Support" is displayed.

If information contains characters other than ID3 tag information, the audio file may not be played back.

The tag information may not be correctly displayed, depending on the contents.

Playing back MP3/WMA/AAC

MP3/WMA/AAC files are prepared, then written to a CD-R, CD-RW using CD-R writing software or stored to a USB Memory. A disc can hold up to 510 files/folders (including Root Folders), and the maximum number of folders is 255. This unit can recognize at most 20 Banks(1000 files per Bank) stored in USB Memory.

Playback may not be performed if a disc or USB Memory exceeds the limitations described above.

Do not make a files playback time more than 1 hour.

Media supported

The media that this device can play back are CD-ROMs, CD-Rs, and CD-RWs.

This device also can play back USB Memory media.

Corresponding File Systems

This device supports disks formatted with ISO9660 Level 1 or Level 2. Under the ISO9660 standard, there are some restrictions to remember. The maximum nested folder depth is 8 (including the root directory). The number of characters for a folder/file name is limited. Valid characters for folder/file names are letters A-Z (all caps), numbers 0-9, and ' _ ' (underscore).

This device also can play back discs in Joliet, Romeo, etc., and other standards that conform to ISO9660. However, sometimes the file names, folder names, etc., are not displayed correctly.

This device also supports FAT 12/16/32 for USB Memory device.

Formats supported

This device supports CD-ROM XA, Mixed Mode CD, Enhanced CD (CD-Extra) and Multi-Session. This device cannot correctly play back discs recorded with Track At Once or packet writing.

Order of files

Files are played back in the order that the writing software writes them to the disc. Therefore, the playback order may not be what is expected. Verify the writing order in the software's documentation. The playback order of the folders and files is as follows.

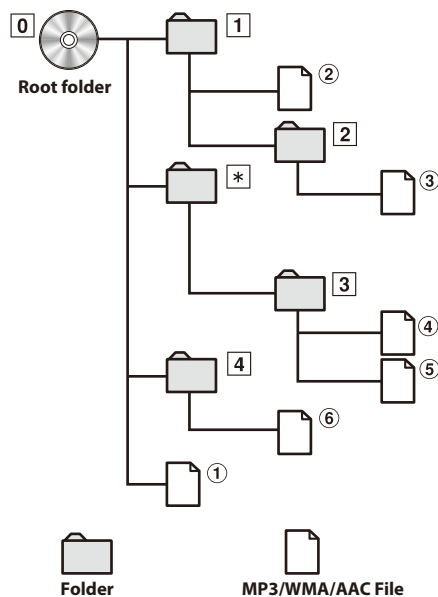

* The folder No./ folder Name will not be displayed if no file is contained in the folder.

Terminology

Bit rate

This is the “sound” compression rate specified for encoding. The higher the bit rate, the higher the sound quality, but also the larger the files.

Sampling rate

This value shows how many times per second the data is sampled (recorded). For example, music CDs use a sampling rate of 44.1 kHz, so the sound is sampled (recorded) 44,100 times per second. The higher the sampling rate, the higher the sound quality, but also the larger the volume of data.

Encoding

Converting music CDs, WAVE (AIFF) files, and other sound files into the specified audio compression format.

Tag

Song information such as track titles, artist names, album names, etc., written into MP3/WMA files.

Root folder

The root folder (or root directory) is found at the top of the file system. The root folder contains all folders and files. It is created automatically for all burned discs.

Sound Setting

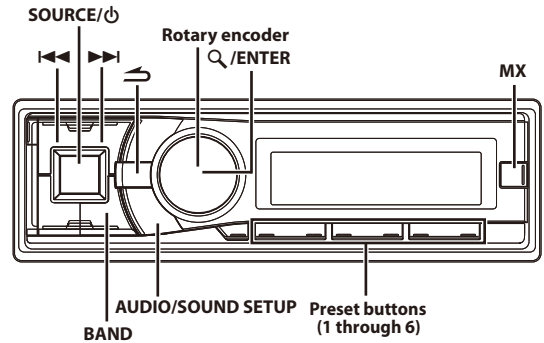

Adjusting Subwoofer Level/Balance (Between Left and Right)/Fader (Between Front and Rear)/Auto Volume/Black Out/Defeat

1 Press AUDIO repeatedly to choose the desired mode.

Each press changes the mode as follows:

SUBWOOFER*¹ → BALANCE → FADER → BLACK OUT*² → DEFEAT → VOLUME → SUBWOOFER

*¹ When the Subwoofer mode is set to OFF, its level cannot be adjusted, refer to "Turning Subwoofer ON/OFF" on page 13.

*² When BLACK OUT mode is turned ON, after 5 seconds, all display indications on this unit will turn off to reduce power consumption. This additional power enhances the sound quality. .

Subwoofer Level	0 ~ 15
Balance	-15(L) ~ 15(R)
Fader	-15(R) ~ 15(F)
Black Out	ON/OFF
Defeat	ON/OFF
ON/OFF	0 ~ 35

Note

- If no operation is performed for 5 seconds after selecting the SUBWOOFER BALANCE, FADER, BLACK OUT or DEFEAT mode, the unit automatically returns to normal mode.
- If any button on the unit is pressed during the BLACK OUT Mode, the function is displayed for 5 seconds before returning to Blackout mode.

2 Turn the Rotary encoder until the desired sound is obtained in each mode.

Note

- Depending on the connected devices, some functions and display indications do not work.

Setting the MX Mode

MX (Media Xpander) makes vocals or instruments sound distinct regardless of the music source. The FM radio, CD, and iPod, will be able to reproduce the music clearly even in cars with a lot of road noise.

- 1 Press **SOURCE/⏻** to select the source to which you want to apply Media Xpander.
- 2 Press **MX** to switch to Media Xpander mode, and then press **Q/ENTER**.
- 3 Turn the **Rotary encoder** to select **ON**, and then press **Q/ENTER**.
The MX Level setting item is displayed.
- 4 Turn the **Rotary encoder** to select the **MX Level**, and then press **Q/ENTER**.
- 5 Turn the **Rotary encoder** to select the desired Media Xpander level, and then press **Q/ENTER**.

FM (MX level 1 to 3):

The medium to high frequencies become clearer, and produces well balanced sound at all frequencies.

CD (MX level 1 to 3):

CD mode processes a large amount of data during playback. MX takes advantage of this large data quantity to reproduce a more clear, clean output.

CMPM (MX level 1 to 3):

This corrects information that was lost at the time of compression. This reproduces a well-balanced sound close to the original.

DVD (Video CD) (MOVIE MX level 1 to 2):

The dialogue portion of a video is reproduced more clearly.

(DVD MUSIC):

A DVD or Video CD contains a large quantity of data such as music clip. MX uses this data to reproduce the sound accurately.

AUX (MX level 1):

Choose the MX mode (CMPM, MOVIE, or MUSIC) that corresponds to the media connected.

- 6 Press and hold **↶** for at least 2 seconds to return to normal mode.

Note

- If **↶** is pressed during setting, the unit returns to the previous item.
- Each music source, such as FM radio, CD and MP3/WMA/AAC can have its own MX setting.
- There is no MX mode for AM radio.
- On disks with both MP3/WMA/AAC and CD-DA, when the source changes from "MP3/WMA/AAC to CD-DA" or "CD-DA to MP3/WMA/AAC", MX-mode switching may delay playback slightly.
- Setting to Non Effect sets MX mode of each music source to OFF.
- If an audio processor with the MX function (PXA-H800, etc.) is connected, its own MX processing is applied to the music source. Since the processor MX settings may not match the head unit, the audio processor needs to be adjusted. For details, refer to the Owner's Manual of the audio processor.
- "CMPM" is applied for MP3/WMA/AAC, Bluetooth Audio and iPod/iPhone.

Sound Setting

You can flexibly customize the unit to suit your own preference and usage. From the SOUND SETUP menu, Audio Setting can be modified.

Use steps 1 to 4 to select one of the setting modes to modify. See the applicable section below for details about the selected setting item.

- 1 Press and hold **SOUND SETUP** for at least 2 seconds to activate the Sound Setting mode.
- 2 Turn the **Rotary encoder** to select the desired sound setting menu, and then press **Q/ENTER**.

HPF*1 ↔ Subwoofer ↔ SUBW. System*2 ↔ SUBW. Phase*2 ↔ SUBW. Channel*2 ↔ Media Xpander*3 ↔ MX Level*3/*4 ↔ EQ Mode ↔ TCR Parameter ↔ Sound Field*5 ↔ HPF

- *1 Adjustment cannot be performed when an external audio processor is connected or DEFEAT is set to ON.
- *2 These functions are inoperable when Subwoofer is set to OFF.
- *3 Refer to "Setting the MX Mode" on page 13.
- *4 This function is inoperable when Media Xpander is set to OFF.
- *5 In step 2, two sound adjustment items (Parametric EQ/Graphic EQ, T.Correction) can be selected in Sound Field Adjustment mode, turn the **Rotary encoder** to select the desired item, and then press **Q/ENTER** to continue to step 3.

- 3 Turn the **Rotary encoder** to change the setting, and then press **Q/ENTER**.

(e.g. Select Subwoofer ON or Subwoofer OFF)

- 4 Press and hold **↶** for at least 2 seconds to return to normal mode.

Note

- Media Xpander, Parametric EQ/Graphic EQ Adjustment, EQ Mode and MX Level Adjustment are inoperable when DEFEAT is set to ON.
- Pressing **↶** returns to the previous Sound menu mode.
- If no operation is performed for 60 seconds, Sound menu mode is cancelled.

Adjusting the High Pass Filter

The High Pass Filter on this unit can be adjusted to suit your personal taste.

■ **Setting item:** HPF

Setting contents:

OFF (Initial setting) / 60 Hz / 80 Hz / 100 Hz

Turning Subwoofer ON/OFF

When the subwoofer is on, you can adjust the subwoofer output level (refer to "Sound Setting" on page 12).

■ **Setting item:** Subwoofer

Setting contents:

OFF / ON (Initial setting)

OFF:

No subwoofer signal is output from the Subwoofer RCA Connectors (refer to "Connections" on page 50).

ON:

The subwoofer signal is output from the Subwoofer RCA Connectors (refer to "Connections" on page 50).

Setting the Subwoofer System

When the subwoofer is on, you can select either System 1 or System 2 for the desired subwoofer effect.

■ **Setting item:** SUBW. System

Setting contents:

1 (Initial setting) / 2

1:

Subwoofer level changes according to the main volume setting.

2:

Subwoofer level change is different from the main volume setting. For example, even at low volume settings, the subwoofer is still audible.

Setting the Subwoofer Phase

The subwoofer output phase is toggled SUBWOOFER NORMAL (0°) or SUBWOOFER REVERSE (180°). To adjust the level, turn the **Rotary encoder**.

■ **Setting item:** SUBW. Phase

Setting contents:

PHASE 0° (Initial setting) / PHASE 180°

Setting the Subwoofer Channel(SUBW. Channel)

You can set the subwoofer output to stereo or monaural. Make sure to set the correct output for your subwoofer type.

■ **Setting item:** SUBW. Channel

Setting contents:

STEREO (Initial setting) / MONO

STEREO:

Subwoofer stereo (L/R) output

MONO:

Subwoofer monaural output.

Setting EQ mode

This setting gives you a choice of 5-band parametric, or 7-band graphic equalizer.

■ **Setting item:** EQ Mode

Setting contents:

Graphic EQ / Parametric EQ (Initial setting)

GEQ:

7-band Graphic EQ.

PEQ:

5-band Parametric EQ.

Setting the Time Correction Unit (TCR Parameter)

You can change the unit, (cm or inch) of time correction.

■ **Setting item:** TCR Parameter

Setting contents:

cm (Initial setting) / inch

Sound Field Adjustment

The setting of Parametric EQ/Graphic EQ and Time Correction can be adjusted in this mode.

Adjusting the Parametric Equalizer Curve

You can modify the Equalizer settings to create a response curve more appealing to your personal taste. To adjust the Parametric Equalizer Curve, set the EQ Mode to Parametric EQ. For details, refer to "Setting EQ mode" on page 14.

1 After selecting Parametric EQ from the Sound Field mode, press BAND to select the band to be adjusted.

Band 1 → Band 2 → Band 3 → Band 4 → Band 5 → Band 1

2 Press \leftarrow or \rightarrow to select frequency bands.

Adjustable frequency bands: 63 Hz to 17.5 kHz (in 1/3 octave steps).

Band-1	63 Hz~200 Hz
Band-2	160 Hz~1 kHz
Band-3	630 Hz~4 kHz
Band-4	1.6 kHz~10 kHz
Band-5	10kHz~17.5kHz

3 Turn the Rotary encoder to adjust the level.

Adjustable level: -6 to +6 dB

4 Press SOURCE/ \cup to set the bandwidth (Q).

Adjustable bandwidth: 1, 2, 3, 4

5 To adjust another band, repeat steps 1 to 4 and adjust all bands.

Note

- While adjusting the Parametric EQ, you should consider the frequency response of the connected speakers.
- The frequency value range of the current band should be higher than the previous band's setting value and lower than the next band's setting value.

Adjusting the Graphic Equalizer Curve

You can modify the equalizer settings to create a response curve more appealing to your personal taste. To adjust the Graphic Equalizer Curve, set the EQ Mode to Graphic EQ. For details, refer to "Setting EQ mode" on page 14.

1 After selecting Graphic EQ from the Sound Field mode, press BAND to select the band to be adjusted.

Band 1 → Band 2 → Band 3 → Band 4 → Band 5 → Band 6 → Band 7 → Band 1

2 Turn the Rotary encoder to adjust the level.

Adjustable level: -6 to +6 dB

3 To adjust another band, repeat steps 1 and 2, and then adjust all bands.

Adjusting the Time Correction

Before performing the following procedures, refer to "About Time Correction" on page 38.

1 After selecting T.Correction from the Sound Field mode, press BAND to select a speaker to be adjusted.

F-L*¹ → F-R*² → R-L*³ → R-R*⁴ → SW-L → SW-R → F-L

*1 Front-L (Initial setting)

*2 Front-R

*3 Rear-L

*4 Rear-R

2 Turn the Rotary encoder to adjust the distance correction value (0.0 to 336.6cm).

L = (distance to farthest speaker) - (distance to other speakers)

3 Repeat steps 1 and 2 to set another speaker.

By setting these values to make its sound reach the listening position at the same time as the sound of other speakers.

Note

- The total adjustment distance for all speakers should be less than 680cm (268.1 inch).

Storing the Sound Field Adjustment Settings

The Sound Field Settings containing Parametric EQ/Graphic EQ and T.Correction settings can be stored in the preset memory.

1 When the settings of Sound Field have been completed, select any one of the preset buttons (1 through 6) in any item of the Sound Field mode (e.g. Parametric EQ), press and hold the desired preset buttons for at least 2 seconds.

2 Turn the Rotary encoder to select Protect YES/NO, and then press Q/ENTER to store the adjusted contents.

Protect YES (Initial setting) ↔ Protect NO

Note

- If YES is selected, the adjusted contents are protected and stored into the preset buttons. When you want to store the parameter into a protected preset button, "Replace NO/YES" can be selected.
- If NO is selected, the preset is stored.
- While perform this operation, all adjusted contents of Parametric EQ/Graphic EQ and T.Correction will be stored in the preset buttons.
- The stored contents are not deleted even when resetting the unit or disconnecting the battery.
- The stored contents can be recalled by performing operation (refer to "Recalling the Stored Sound Field Adjustment Settings" on page 15).

Recalling the Stored Sound Field Adjustment Settings

The stored Sound Field Settings contain Parametric EQ/Graphic EQ and T.Correction settings that are stored in the preset memory.

1 After selecting any item of the Sound Field mode (e.g. Parametric EQ), press any one of the preset buttons (1 through 6) that has your desired characteristic in memory to recall the stored settings.

2 Press the preset buttons (1 through 6) again to return to the Sound Field mode.

Note

- While performing this operation, all adjustment contents of Parametric EQ/Graphic EQ and T.Correction stored in the preset buttons will be recalled.

Other Functions

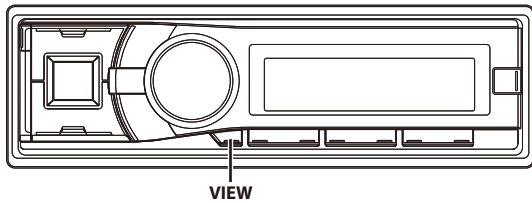

Displaying the Text

Text information, such as the disc name and the track name, will be displayed if playing a CD text compatible disc. It is also possible to display the folder name, the file name and the tag, etc., while playing MP3/WMA/AAC files.

Press VIEW.

The display will change every time the button is pressed.

Note

- When the Text Scroll is set to Manual, press and hold **VIEW** for at least 2 seconds, the current text will be scrolled one time (except Radio mode).

The display in Radio mode:

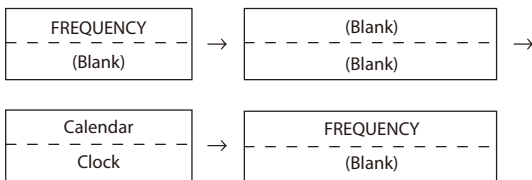

The display in CD mode:

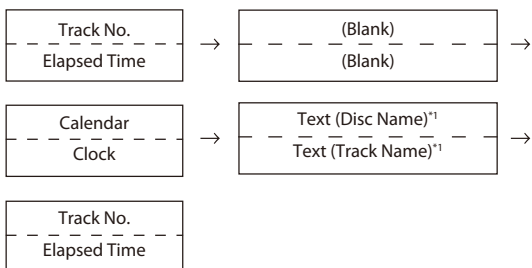

The display in MP3/WMA/AAC mode:

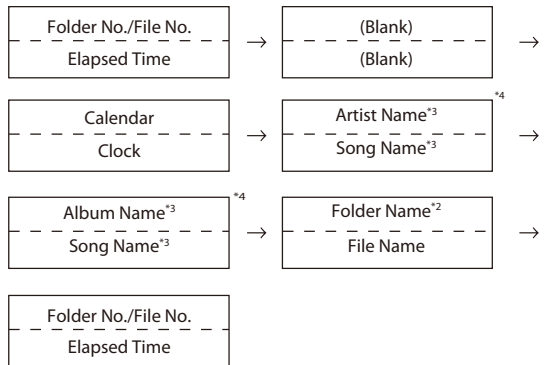

The display in Bluetooth Audio mode:

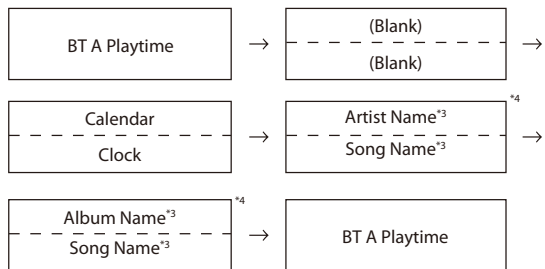

*1 Displayed during playback of a disc with CD Text. If there is no text information, nothing will be displayed.

*2 The root folder of disc/USB Memory is displayed as “\ROOT”. If there is no text information, nothing will be displayed.







*3 If an MP3/WMA/AAC file contains ID3 tag/WMA tag information, the ID3 tag/WMA tag information is displayed (e.g., song name, artist name, and album name). All other tag data is ignored.

If there is no text information, nothing will be displayed.

*4 When the Text Scroll (refer to “Scroll Setting (Text Scroll)” on page 20) is set to “Auto”, the display cannot be switched by pressing **VIEW**. The display contents switch alternately.

About the indication display

When displaying Text, the following indicators are lit according to the mode.

Indicator/ Mode	CD Mode	MP3/WMA/AAC Mode	iPod/iPhone/ Bluetooth Audio Mode
	—	Folder Name being displayed	—
	—	Artist Name being displayed	Artist Name being displayed
	—	Album Name being displayed	Album Name being displayed
	—	File Name being displayed	—
	Text (Disc Name) being displayed	—	—
	Text (Track Name) being displayed	Song Name being displayed	Song Name being displayed

About "Text"

Text compatible CDs contain text information such as the disc name and track name. Such text information is referred to as "text".

Note

- Some characters may not be displayed correctly with this device, depending on the character type.
- The CD changer must also be CD Text compatible for the Text information to be displayed.
- If there is no TEXT information, the display is blank.
- The text or tag information may not be correctly displayed, depending on the contents.

Displaying Time

Press **VIEW** repeatedly until the time is displayed.

Each press changes the display.
For details, refer to "Displaying the Text" on page 16.

Note

- Selecting any tuner or CD function while in the clock priority mode will interrupt the time display momentarily. The function selected will be displayed for about 5 seconds before the time returns to the display.

SETUP

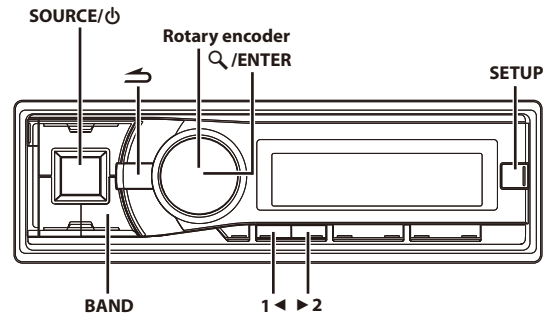

Setting

You can flexibly customize the unit to suit your own preferences and usage. From the **SETUP** menu, General Setting, Display Setting, etc. can be modified.

Use steps 1 to 5 to select one of the **SETUP modes to modify. See the applicable section below for details about the selected **SETUP** item.**

- 1 Press and hold **SETUP** for at least 2 seconds to activate the **SETUP** mode.
- 2 Turn the **Rotary encoder** to select the desired item, and then press **Q/ENTER**.

Bluetooth*1 ↔ General ↔ Display ↔ Tuner ↔ USB ↔ Bluetooth
(e.g. Select General)

- 3 Turn the **Rotary encoder** to select the desired item, and then press **Q/ENTER**.

(e.g. Select Power IC)

General:

Birthday Set ↔ Clock Mode ↔ Clock Adjust*2 ↔ Calendar ↔ Play Mode ↔ Beep ↔ Digital AUX ↔ D.AUX Name*3 ↔ AUX IN ↔ AUX Name*4 ↔ AUX1*5 ↔ AUX2*5 ↔ Power IC ↔ Demo ↔ Steering ↔ Birthday Set

Displayed:

Illumination ↔ Dimmer ↔ Dimmer Level ↔ Scroll Type ↔ Text Scroll ↔ Font Select ↔ BGV Select ↔ Opening MSG ↔ Illumination

Tuner:

FM Tuner Set

USB:

USB Search ↔ USB Skip

*1 Refer to "BLUETOOTH SETUP" on page 21.

*2 Refer to "Setting the Time and Calendar" on page 8.

*3 Displayed only when Digital AUX is ON.

*4 Displayed only when AUX IN is ON.

*5 Displayed only when KCA-410C is connected and AUX IN is ON.

4 Turn the **Rotary encoder** to change the setting, and then press **Q/ENTER**.

P(e.g. Select Power IC ON or Power IC OFF)

5 Press and hold **SETUP** for at least 2 seconds to return to normal mode.

Note

- Pressing **↶** returns to the previous **SETUP** mode.
- If no operation is performed for 60 seconds, **SETUP** is cancelled.

General Setting

General is selected on the setup main menu in step 2.

Birthday Opening Message Setting (Birthday Set)

While Opening MSG is set to ON (refer to "Opening Message ON/OFF Setting" on page 20), and then input your birthday details, a message can be displayed on that day. Turn the **Rotary encoder** to set "mm" (Month), and then press **Q/ENTER**. Turn the **Rotary encoder** again to set "dd" (Date).

■ **Setting item:** Birthday Set

Setting contents:
mm/dd

Setting the Clock Display (Clock Mode)

You can select the clock display type, 12-hour or 24-hour, depending on your preference.

■ **Setting item:** Clock Mode

Setting contents:
AM (Before noon) 12:00 (12-hour) (Initial setting)/ 00:00 (24-hour)

Setting of Calendar Display Pattern Switching (Calendar)

You can switch the calendar display pattern to be shown when the time is displayed.

■ **Setting item:** Calendar

Setting contents:
mm/dd/yyyy / dd/mm/yyyy (Initial setting) / yyyy/mm/dd

yyyy :
Shows the year

mm :
Shows the month.

dd :
Shows the day

ex. dd/mm/yyyy → 01/01/2012

Playing MP3/WMA/AAC Data (Play Mode)

This unit can play back CDs containing both CD and MP3/WMA/AAC data (created in Enhanced CD (CD Extra) format). However, in some situations, playback of an enhanced CD may be difficult. In this case, you can select playback of a single session only, containing the CD data. When a disc contains both CD and MP3/WMA/AAC data, playback starts from the CD data portion of the disc.

■ **Setting item:** Play Mode

Setting contents:

CD-DA (Initial setting) / CDDA&MP3/WMA

CD-DA :

Only the CD data in Session 1 can be played back.

CDDA&MP3/WMA:

CD data, MP3/WMA/AAC files in mixed mode, and multi-session discs can be played back.

Note

- Perform this setting before inserting a disc. If a disc has already been inserted, remove it first. (If you use an MP3 changer, you have to change discs.)

Sound (Beep) Guide Function

This function will give audible feedback with varying tones depending upon the button pressed.

■ **Setting item:** Beep

Setting contents:

OFF / ON (Initial setting)

Setting the External Digital Input

When an ALPINE Ai-NET compatible digital audio processor (PXA-H800) and a DVD player (DVE-5207) not compatible with Ai-NET are connected, set Digital AUX to ON to enjoy 5.1-channel surround sound.

You can change the Digital AUX name display when Digital AUX is set to ON. Press **Q/ENTER** when Digital AUX is set to ON, and select Digital AUX name by turning the **Rotary encoder**, then press **Q/ENTER**. After that, turn the **Rotary encoder** to select the desired Digital AUX name.

■ **Setting item:** Digital AUX

Setting contents:

OFF (Initial setting) / ON

Note

- Press **SOURCE/⏻**, and select the D.Aux mode, and adjust the volume, etc.
- After input selection is completed, turn the ignition off and back on again. Setting of the optical digital input switch is completed.
- Depending on the connected audio processor, DVD player sound may continue to be output, even though the source is changed to another one. If this occurs, set the DVD player's power to OFF.

Setting the AUX Mode (V-Link)

You can input TV/video sound by connecting an optional Ai-NET/RCA Interface cable (KCA-121B) or Versatile Link Terminal (KCA-410C) to this component.

You can change the AUX name display when AUX IN is set to ON. Press **Q/ENTER** when AUX IN is set to ON, and select AUX Name by turning the **Rotary encoder**, and then press **Q/ENTER**. After that, turn the **Rotary encoder** to select the desired AUX name. If the KCA-410C is connected, it is possible to select two AUX names.

■ **Setting item:** AUX IN

Setting contents:

OFF (Initial setting) / ON

OFF:

When set to OFF, AUX source cannot be selected.

ON*:

Set to ON when a portable device is connected. If **SOURCE/⏻** is pressed and AUX is selected, the sound of the portable device is input to the unit.

- * You can change the AUX Name display when AUX IN is set to ON. Press **Q/ENTER** when AUX IN is set to ON, and select AUX Name by turning the Rotary encoder, then press **Q/ENTER**. After that, turn the Rotary encoder to select the desired AUX Name.

Note

- Via KCA-410C, up to 2 external devices with RCA output can be connected. In this case, press **SOURCE/⏻** to select AUX mode and then press **BAND** to select your desired device.

Connecting to an External Amplifier

When an external amplifier is connected, sound quality can be improved by stopping the power supply of the built-in amplifier.

Setting item: Power IC
Setting contents:

OFF / ON (Initial setting)

OFF:

Use this mode when the line output of this unit is used to drive an external amplifier. In this setting, the head unit's internal amplifier is turned OFF and can not drive speakers.

ON:

The speakers are driven by the built-in amplifier.

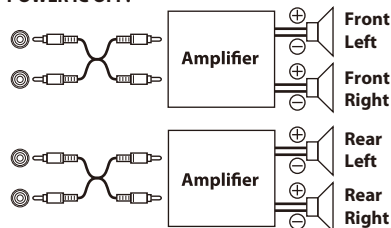
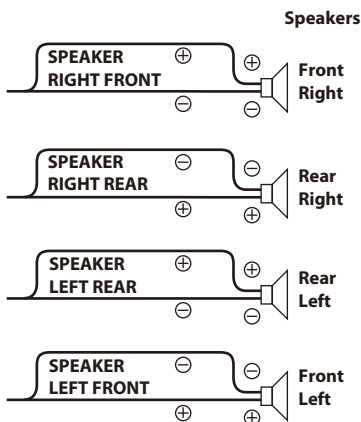
POWER IC OFF:**POWER IC ON:****Note**

- No sound is produced by the system when the Power IC is set to OFF

Demonstration

This unit has a demonstration feature for the display.

Setting item: Demo
Setting contents:

OFF (Initial setting) / ON

Note

- To quit Demo mode, set to Demo OFF.

Display Setting

Display is selected on the setup main menu in step 2.

Changing Lighting Colour

You can change the lighting colour of the unit's buttons.

Setting item: Illumination
Setting contents:

TYPE1 (Initial setting) / TYPE2 / TYPE3

TYPE 1:

When the colour of **SOURCE/⏻** is blue, the colour of the other is blue.

TYPE 2:

When the colour of **SOURCE/⏻** is blue, the colour of the other is red.

TYPE 3:

When the colour of **SOURCE/⏻** is red, the colour of the other is red.

Dimmer Control

Set the Dimmer Control to Auto to decrease the illumination brightness of the unit with the head lights of the vehicle ON. This mode is useful if you felt the unit's backlighting is too bright at night.

Setting item: Dimmer
Setting contents:

Auto(Initial setting)/Manual

Dimmer Level Setting

In the Dimmer Level setting, three levels are available, the highest level (Lev3) being the dimmest when the car headlights are on.

Setting item: Dimmer Level
Setting contents:

Lev1 (Initial setting) / Lev2 / Lev3

Scroll Type Setting

Choose from two scrolling methods. Select the type you prefer.

■ Setting item: Scroll Type

Setting contents:

TYPE 1 / TYPE 2 (Initial setting)

TYPE 1:

The characters scroll from right to left, one character at a time, until the entire title has scrolled.

TYPE 2:

Words are built up from left to right, a single character at a time. When the display is full, it is cleared and the subsequent words are displayed the same way until all words of the title have been shown.

Scroll Setting (Text Scroll)

This CD player can scroll the disc and track names recorded on CD-TEXT discs, as well as the text information of MP3/WMA/AAC files, folder names, and tags.

■ Setting item: Text Scroll

Setting contents:

Manual (Initial setting) / Auto

Text Scroll Manual:

The above information is scrolled only when a disc is loaded, a channel or track is changed, etc.

Text Scroll Auto:

CD text information, folder and file names, and the tag information are scrolled continuously.

Note

- In parts of the display, scrolling may not occur, or scroll content may differ.

Switching the Character Font

Two types of font can be selected. You can select the font type you like.

■ Setting item: Font Select

Setting contents:

TYPE 1 (Initial setting) / TYPE 2

Switching the Animation Display Type (BGV Select)

You can select your favourite animation display for background from 4 types.

■ Setting item: BGV Select

Setting contents:

OFF (Initial setting) / TYPE 1 / TYPE 2 / TYPE 3 / TYPE 4

Opening Message ON/OFF Setting

This unit includes a special message feature with various patterns, which when enabled displays opening messages for certain occasions. For example, when you turn this unit on December 25th (according to the unit's date setting), a Christmas greeting is displayed if the Opening Message is set to ON.

■ Setting item: Opening MSG

Setting contents:

OFF (Initial setting) / ON

Tuner Setting

Tuner is selected on the setup main menu in step 2.

Setting the TUNER (FM) tone quality

This unit can set your preferred tone quality for FM radio source.

■ Setting item: FM Tuner Set

Setting contents:

Normal (Initial setting) / HiFi / Stable

Normal:

Standard setting.

HiFi:

High-quality setting.

Stable:

Control noise.

Note

- Noise may be more noticeable when HiFi is set, depending on the reception status. In this case, the Normal setting is recommended.

USB Setting

"USB" is selected on the setup main menu in step 2.

Setting the USB Search Mode

This unit allows searching MP3 Tag info or file names on Flash Memory devices. Only compatible audio files are displayed during the search.

■ Setting item: USB Search

Setting contents:

Tag (Initial setting) / File Name

Tag:

When Tag is selected, you can use Playlists/Artists/Albums Songs/ Genres/Composers/Folders/Files search mode to narrow searches.

File Name:

When File Name is selected, you can search a folder/file as search files on PC.

Note

- After the above setting, turn the ignition key off (ACC OFF) and on again (ACC ON).
- For search mode details, refer to "Searching for a desired Song" on page 28.

Setting the USB Skip function

During (FILE NAME) searching, you can skip over designated folders/files by pressing and holding **1◀** / **▶2** for at least 2 seconds. For example, if you select 10File in the (FILE NAME) searching mode, by pressing and holding **1◀** you can skip forward 10 folders/ files from the current folder/file; by pressing and holding **▶2** you can skip backward 10 folders/files from the current folder/file. If the folders/files searched are less than the assigned skipped-over ones, pressing and holding **1◀** / **▶2** will skip to the first or last folder/file.

■ Setting item: USB Skip

Setting contents:

10File (Initial setting) / 20File / 50File / 100File

BT Hands Free Calling

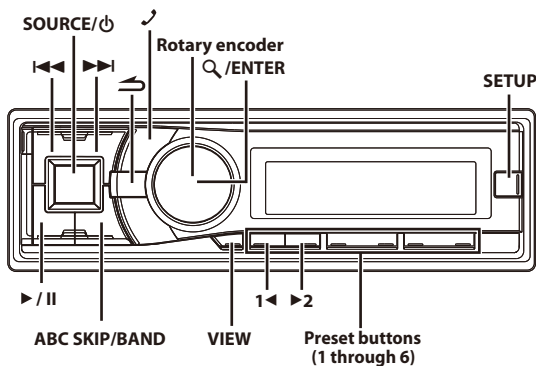

Setup Before Using

About BLUETOOTH

BLUETOOTH is a wireless technology allowing communication between a mobile device or personal computer over short distances. This enables a hands-free call or data transmission between BLUETOOTH compatible devices. BLUETOOTH transmission is available in the unlicensed 2.4 GHz spectrum if the distance between devices is within 10 meters. For details, refer to the BLUETOOTH Home page (<http://www.bluetooth.com>).

Note

- Depending on the BLUETOOTH version, a BLUETOOTH compatible device may not be able to communicate with this unit.
- Proper function of this unit with all BLUETOOTH compatible devices is not guaranteed. For handling of the BT compatible device, consult your ALPINE dealer or ALPINE website.
- Depending on the surroundings, BLUETOOTH wireless connection may be unstable.
- When you place a call, or perform setup operations, be sure to stop your car in a safe place.
- Depending on the connected BLUETOOTH compatible device(s), the function may differ. Also refer to the Owner's Manual of the connected device(s).
- When you search for this unit using the BLUETOOTH compatible phone, the unit name is displayed as "Alpine CD Receiver".

Before Using BLUETOOTH Function

Before using the BLUETOOTH function, the following settings need to be made.

Set "HFP" or "Audio" to ON when you want to use Hands-Free phone or Bluetooth Audio function. Refer to "Setting the BLUETOOTH Connection (BT IN)" on page 22.

Note

- Before using BLUETOOTH function, it must be paired with this unit. Refer to "How to connect to a BLUETOOTH compatible device (Pairing)" on page 21.

How to connect to a BLUETOOTH compatible device (Pairing)

For details on the control from a BLUETOOTH compatible device, refer to the Owner's Manual of the BLUETOOTH compatible device.

Pairing a BLUETOOTH compatible device with SSP (Secure Simple Pairing)

- 1 Using your BLUETOOTH compatible device, select the "Alpine CD Receiver" for pairing.
- 2 Turn the Rotary encoder to change the head unit display from "Pairing NO" to "Pairing YES", and then press Q/ENTER.
If "Pairing NO" is selected, the connection will be cancelled.
- 3 If the pairing was successful, "Connected" is displayed for a few seconds. The head unit then returns to its previous state.

Pairing a BLUETOOTH compatible device without SSP (Secure Simple Pairing)

- 1 Using your BLUETOOTH compatible device, select the "Alpine CD Receiver" for pairing.
 - 2 Input the Passcode ("0000") in a BLUETOOTH compatible device.
- Note**
- The Passcode is fixed as "0000".
- 3 If the pairing was successful, "Connected" is displayed for a few seconds. The head unit then returns to its previous state.

Note

- If the connection is unsuccessful, "Failed" is displayed.
- After a successful pairing, the two devices should re-pair automatically whenever the vehicle's ignition is turned ON. However, the re-pairing may fail. If the auto re-pairing fails, try to pair manually.
- Set "Visible Mode" to ON to enable this unit to be recognised by a BLUETOOTH compatible device, refer to "Setting the Visible Mode" on page 22.
- You can also manually pair the BLUETOOTH devices from this unit. For details, refer to "Pairing a BLUETOOTH Device from the unit" on page 22.

BLUETOOTH SETUP

The following steps 1 to 5 are common to the various BLUETOOTH functions. For details, refer to each individual function

Note

- Set "HFP" or "Audio" to ON, and then perform BLUETOOTH SETUP operation. Refer to "Setting the BLUETOOTH Connection (Bluetooth IN)" on page 22.

- 1 Press and hold **SETUP** for at least 2 seconds to activate the **SETUP** mode.
- 2 Turn the **Rotary encoder** to select "Bluetooth", and then press **Q/ENTER**.

The BLUETOOTH setup mode is activated.

- Turn the **Rotary encoder** to select the desired items, and then press **Q/ENTER**.

BLUETOOTH:

Bluetooth IN*1 ↔ Paired Device ↔ Visible Mode*1 ↔ Search Device*1 ↔ Call Sound*2 ↔ Sender ID*2 ↔ PB Update*2 ↔ PB Order*2 ↔ Auto Answer*2 ↔ Service Name*2 ↔ Speaker select*2 ↔ FW version ↔ FW Update*1

*1 The items are not displayed during a phone call.

*2 The items are not displayed when "HFP" is set to OFF. Refer to "Setting the BLUETOOTH Connection (BT IN)" on page 22.

- Turn the **Rotary encoder** to change the settings.

- Press and hold **SETUP** for at least 2 seconds.

The SETUP mode is cancelled.

Note

- Press **↶** to return to the previous mode.
- Pressing and holding **↶** for at least 2 seconds will return to normal mode.
- If no operation is performed for 60 seconds, the unit will return to normal mode automatically.

Setting the BLUETOOTH Connection (BT IN)

With BLUETOOTH technology, you can place a hands-free call by a BLUETOOTH-equipped mobile phone. Audio information of a BLUETOOTH compatible mobile phone, a portable audio player, etc., is controllable/playable wirelessly from this unit.

■ **Setting item:** Bluetooth IN

■ **Further setting items:** HFP / Audio

Setting contents:

OFF / ON (Initial setting)

Hands-Free Phone setting (HFP)

ON:

Select when you want to pair your BLUETOOTH compatible phone with this unit.

OFF:

Hands-Free Phone function is not used.

Note

- When HFP is set to OFF, the indicators related to Hands-free phone (🔋 battery quantity, 📶 signal strength and 📧 message) will not be displayed.

BLUETOOTH Audio setting (Audio)

ON:

Select when you want to use BLUETOOTH Audio function.

OFF:

BLUETOOTH Audio function is not used.

Setting the BLUETOOTH Device

Select one of 3 connected BLUETOOTH compatible devices that you previously registered.

■ **Setting item:** Paired Device

- Turn the **Rotary encoder** to select a BLUETOOTH compatible device you want to use (you want to change connection) and then press **Q/ENTER**.

- Turn the **Rotary encoder** to select "Connect" to connect the selected device.

The connected device is marked with "✳". Select "Disconnect" to disconnect this device. Select "Clear" when you want to clear the device from the device list.

Note

- If the connection is successfully changed, "Connected" is displayed for 2 seconds.
- If a mobile phone is connected to this unit successfully, the 🔋 indicator lights up to show the battery quantity of the connected mobile phone. The 🔋 indicator lights up when the battery quantity is in middle level, and it blinks in low level.
- Indicator 📶 (Signal Strength): The indicator will display the current signal strength of mobile phone. The indicator blinks when the signal of the connected mobile phone is weak.
- Depending on the connected mobile phone, the 🔋 (battery quantity), 📶 (signal strength) and 📧 (message) indicators may not be displayed.
- If all the 3 positions have been registered, you cannot register the 4th device. To register another device, you need to delete one of the devices from position 1 to 3 first.

Setting the Visible Mode

You can set whether this unit can be recognised or not from a BLUETOOTH compatible device. Normally set this to ON.

■ **Setting item:** Visible Mode

Setting contents:

OFF / ON (Initial setting)

OFF:

Disable recognition of this unit from the BLUETOOTH compatible device.

ON:

Enable recognition of this unit from the BLUETOOTH compatible device.

Pairing a BLUETOOTH Device from the unit

If your BLUETOOTH device is not immediately pairing, the head unit can perform a search. The search can find paired or unpaired devices.

■ **Setting item:** Search Device

- When Search Device is selected and "Searching" is displayed, the search gets started

Note

- The "Searching" operation can be stopped by pressing **↶**.

- Turn the **Rotary encoder** to select the name of the device to be connected from the Device Search list and then press **Q/ENTER**.

- If this unit is successfully connected to a BLUETOOTH compatible device, "Connected" is displayed, and then the unit returns to normal mode.

Depending on the mobile phone, it may be necessary to input a passcode. In this case, "PASSCODE 0000" is displayed. Input the passcode "0000" in the BLUETOOTH compatible device to make the pairing. After the pairing is completed, the unit will automatically connect to the BLUETOOTH compatible device. If you input the wrong passcode or the communication fails, "Failed" is displayed.

Setting the BLUETOOTH sound quality

Change these settings to improve the quality of the outgoing or incoming call.

■ **Setting item:** Call Sound

■ **Further setting items:** Vol LV Adj / Type Set

Adjusting the volume (VOL LV Adj)

You can emphasize or weaken the volume level of the Phone call, the ring tone and the microphone input to fit your own preferences.

Setting contents:

- Phone Talk:
-5 ~ +5 dB
- Ring Tone:
-5 ~ +5 dB
- MIC Gain:
-5 ~ +5 dB

Sound Type setting (Type Set)

Depending on your calling environment, choose one of the settings below which gives the best sound quality.

Setting contents:

TYPE1 (Initial setting) / TYPE2 / TYPE3 / TYPE4 / TYPE5

TYPE1:

Standard Mode (recommended)

TYPE2:

Enhance the noise reduction

TYPE3:

Enhance the echo-cancel

TYPE4:

Enhance both noise reduction and echo-cancel

TYPE5:

Weaken both noise reduction and echo-cancel

Note

- The functions below are designed to improve the sound quality of the caller to driver.
Noise reduction: This function can reduce the road noise, but excessive enhancement may affect the sound quality of calling.
Echo-cancel: This function can reduce the echo noise, but excessive enhancement may affect the sound quality of calling..

Setting the caller information display/text message indicator ON/OFF

You can choose whether to use these functions according to the following setting.



■ **Setting item:** Sender ID

■ **Further setting items:** Short Message / Telephone

Setting contents:

OFF / ON (Initial setting)

Setting text message indicator ON/OFF (Short Message)

When it is set to ON, the  indicator blinks for 30 seconds while receiving a text message. The  indicator remains on if there is an unread text message on the connected mobile phone.

Note

- Depending on the mobile phone, this function may not be performed.
- The text of the message will not be displayed on this unit.
- When this unit prompts you of a received text message, it is recommended to read the message after stopping your car in a safe place, rather than read it immediately through your phone.

Setting the caller information display ON/OFF (Telephone)

If you want to keep the ID information of the caller from others, set this item to OFF. While you are dialing a number, telephone name will be displayed as "No Name". While a call is dialing in or during a call, "NO Name" will be displayed.

Phone Book Auto Update ON/OFF

You can set whether to update the phone book automatically.

■ **Setting item:** PB Update

Setting contents:

OFF / ON (Initial setting)

OFF:

The phone book will not update.

ON:

When the mobile phone reconnects with this unit, the phone book will update.

Changing the Phone book List Order

The phone book is listed alphabetically by the first letter of First or Last Name.

Listing by First Name is the default but Last Name can be selected.

■ **Setting item:** PB Order

Setting contents:

First Name (Initial setting) / Last Name

Note

- "Waiting" will be displayed while the Phone book order is switching. You can quit the "Waiting" screen to perform other operations by pressing  when the ordering is still in progress. At this time, the phone book is not accessible. In addition, the ordering may affect the playback of Bluetooth Audio.

Setting the Received Calls automatically (Auto Answer)

When a call is received, you can set whether to receive it automatically or not.

■ **Setting item:** Auto Answer

Setting contents:

OFF (Initial setting) / ON

OFF:

When a call is received, it is not answered automatically. Press  to receive the call.

ON:

When a call is received, it is answered automatically after about 5 seconds.

Note

- If the received call setting on the mobile phone is on, the call will be answered automatically even though this setting is set to OFF.

Displaying the phone service provider name

The service provider name of the connected BLUETOOTH compatible device will be displayed. If a BLUETOOTH compatible device is not connected, "ID UNSENT" will be displayed.

■ **Setting item:** Service Name

Note

- Depending on the character type, some phone service provider name cannot be displayed. "ID UNSENT" will be displayed.

Selecting the output speaker

You can select the connected speaker in car to output the sound signal of telephone.

■ **Setting item:** Speaker Select

Setting contents:

ALL (Initial setting) / F-L / F-R / F-LR

ALL:

The sound be output from all of speakers in car.

F-L:

The sound only be output from the front left speaker.

F-R:

The sound only be output from the front right speaker.

F-LR:

The sound be output from the front left and front right speaker.

Displaying the firmware version

The current firmware version will be displayed.

■ **Setting item:** FW Version

Updating the firmware

Future BLUETOOTH firmware updates may become available for phone interoperability.

For information to update your BLUETOOTH firmware, please visit Alpine Asia home page (<http://www.alpine-asia.com>).

■ **Setting item:** FW Update

Setting contents:

NO (Initial setting) / YES

Hands-Free Phone Control

About the Hands-Free Phone

Hands-free calls are possible when using a HSP (Head Set Profile) and HFP (Hands-Free Profile) compatible mobile phone with this unit.

Note

- Avoid performing a hands-free call in heavy traffic or on narrow or winding streets.
- Close the windows while calling to reduce background noise.
- If both calling parties are using hands-free devices, or the call is made in a noisy location, difficulty hearing the other person's voice is normal.
- Depending on telephone line conditions or certain mobile devices used, voices may sound unnatural.
- When using a microphone, speak as directly as you can into the microphone to pick up the best sound quality.
- Certain mobile phone features are dependent on the capabilities and settings of your service provider's network. Additionally, certain features may not be activated by your service provider, and/or the provider's network settings may limit the feature's functionality. Always contact your service provider about feature availability and functionality. All features, functionality, and other product specifications, as well as the information contained in the Owner's Manual are based upon the latest available information and are believed to be accurate at the time of printing. Alpine reserves the right to change or modify any information or specifications without notice or obligation.

Answering a Call

Incoming calls are announced by the received call ring tone and a displayed message (PHONE).

Press .

The call starts.

Note

- When "Auto Answer" is set to ON, you can receive a call automatically. Refer to "Setting the Received Calls automatically (Auto Answer)" on page 24.
- While calling, the source sound on the unit is muted. After calling, playback will resume.

Hanging up the Telephone

Press .

The call finishes.

Note

- You can also hang up the call by pressing and holding  for at least 2 seconds.

Calling

Call History is recorded for the last dialed/received/missed calls (80 records for each). There are various ways of making calls based on the "Calling". The following steps 1 to 5 are common to the various ways of making these calls. For details, refer to each individual category for making calls.

1 Press .

The outgoing method list is displayed.

2 Turn the Rotary encoder to select the outgoing mode.

Setting contents:

Voice Dial / Dialed Call / Received Call / Missed Call / Phone Book

Voice Dial:

Voice dial operation

Dialed Call:

Dialed history

Received Call:

Received history

Missed Call:

Missed incoming history

Phone Book:

Mobile phone book

3 Press .

The outgoing mode is activated, and each mode list is displayed.

Note



- It may take some time for the list to be displayed, and also directly after connection, the list may not be brought up to date.

4 Turn the Rotary encoder to select a name or a telephone number from the list.

Note

- You can use Phone book alphabet search function to search a name or number from Phone Book. For details, refer to "Phone book Alphabet Search Function" on page 26.

5 Press .

The selected telephone number will be called. If one name has several numbers registered in the telephone book, press  after selecting the name*, then turn the Rotary encoder to choose the desired number and press , the telephone will be called. Press and hold  for at least 2 seconds after selecting the name, the default number of the name will be called. Depending on the connected mobile phone, this function may not be performed.

* If the name cannot be recognised, "NO Name" will be displayed.

Note

- Press  to return to the previous mode.
- If no operation is performed for 60 seconds, the unit will return to normal mode automatically.
- The names registered in the telephone book are displayed. If the name is not registered, a number is displayed. If both name and number cannot be displayed, "NO Name,NO Number" will be displayed.

Voice Dial Operation

You can make a call using voice commands.

Setting item: Voice Dial

When the Voice Dial mode is activated "Speak" is displayed. Say the telephone number*, name* you want to call into the microphone.

* This message depends on the voice tag prestored in the mobile phone.

Note

- You can perform this operation only when a voice dial compatible mobile phone is connected. If the mobile phone is not compatible with the voice dial, "No Support" is displayed for 2 seconds
- The Voice Dial function performance depends on the recognition range of the mobile phone and mounting location of the microphone. Please pay attention when the microphone is mounted.
- Voice dial operation depends on the function of the mobile phone. For details, refer to the Owner's Manual of the mobile phone.
- If a called person that you say is not found, "No Call" is displayed for 2 seconds.

Redialing a Number In Outgoing History

Previously dialed telephone numbers are stored in dialed calls history. You can redial a number by searching from dialed calls history.

Setting item: Dialed Call

Dialing a Number In Incoming History

Telephone numbers from received calls are stored in the Received List. You can redial these numbers by searching here.

Setting item: Received Call

Dialing a Number In Incoming Missed Call History

Telephone numbers for received calls that are missed, are stored in the Missed List. You can redial these numbers by searching here.

Setting item: Missed Call

Dialing a Number In The Phone Book

Up to 1,000 names (at most 5 telephone numbers for each name) are downloadable from a mobile phone. Dial a call by selecting a person from the phone book list.

Setting item: Phone Book

Note

- The order of the list display depends on the setting of "PB Order" (refer to "Changing the Phone book List Order" on page 23).
- If the call history or phone book of the mobile phone is added or deleted while it is connected to the unit, the list displayed on the unit may not be brought up to date. If it is not updated, you cannot correctly place a call.
- You can display the information of a number stored in phone book by pressing **VIEW**.
If the information can not be obtained, "NO Name" or "NO Number" will be displayed.

Phone book Alphabet Search Function

You can select the first three letters to search for a desired name in phone book list by using the Phone book alphabet search function.

For example:

Searching a name "Michael James"

The following example explains how the search is performed.

Depending on the setting in PB Order (refer to "Changing the Phone book List Order" on page 23), the phone book is listed in first name or last name order. Please search for the first name or last name according to the setting.

1 Press ABC SKIP while in the phone book list, the phone book alphabet search mode is activated.

The letter selection list is displayed.

2 Turn the Rotary encoder to select the first letter (e.g. M), and then press ►►.

The letter selection list is displayed.

3 Turn the Rotary encoder to select the second letter (e.g. I), and then press ►►.

The letter selection list is displayed.

4 Turn the Rotary encoder to select the third letter (e.g. C), and then press Q/ENTER.

The names stored in phone book which begin with "MIC" are searched.

5 Turn the Rotary encoder to select the desired name (e.g. Michael James), and then press Q/ENTER to make the call.

Note

- If the selected name has several numbers registered in phone book, you need to turn the **Rotary encoder** to select the desired number, and then press Q/ENTER.
- Press I◀ in step 3 or 4 to delete the current entry and return to the previous step.
- You can search for a name by its first letter, first two letters or first three letters. Press Q/ENTER after entering the desired number of letters. A list displays the names beginning with the entered letter(s).

Call waiting function

If a second call is received during a current call, you can have the first caller wait momentarily while you take the second call. When you are finished with one call, you can switch to the other one.

If a second call is received during the current call (call1), the information of second caller (call2) is displayed instead of the current caller's name. Press ►2, the call waiting mode is activated.

In this case, call1 is on hold, while you take call2.

Note

- In the call waiting mode, press 1◀ or ►2 to switch between the calling person and the person on hold.
- In the call waiting mode, press and hold 1◀ or ►2 for at least 2 seconds to hang up call1 or call2, and the other call will be answered automatically.
- In the call waiting mode, you can press **VIEW** to change the display between waiting number (1 or 2) and caller name.

Preset a number in the Phone Menu (Shortcut dial)

Assign numbers that you dial frequently to presets for quick recall. You can assign up to six frequently called phone numbers to number presets.

Select a number you want to preset from the Phone Menu list (Phone Book, Dialed Call, etc.). Press and hold any one of the preset buttons (1 through 6) as the one that you wish to store the number for at least 2 seconds.

The phone number you selected is stored in presets.

Note

- If the name has several numbers registered in the phone book, press Q/ENTER after selecting the name. Turn the **Rotary encoder** to choose the desired number. Press and hold any one of the **preset buttons (1 through 6)** for at least 2 seconds. The selected number is stored as a preset number.
- A total of 18 phone numbers can be stored in the preset memory (6 numbers for each mobile phone in the paired device list). If a mobile phone is deleted from the paired device list, the stored preset numbers of this mobile phone are deleted, even when it is paired again.
- If you store a phone number in a preset with a previously stored number, the current number will be cleared and replaced by the new one.

Dialing the preset number

1 Press any one of the preset buttons (1 through 6) that has had a number stored in the phone mode.

The information (name/number) stored in the preset station is displayed.

2 Press Q/ENTER or ↶.

The stored preset number is dialed directly.

Adjusting the volume when receiving a Call

While calling, you can adjust the volume.

Turn the Rotary encoder to adjust the volume.

Note

- You may need to increase volume from your regular audio listening source level. However, increasing the volume excessively may result in feedback. Feedback is directly related to the volume. Turning down the volume as low as acceptable, will reduce it. Positioning the microphone in a direction away from the main car speakers (e.g. clipped on sun visor) may also reduce feedback at high volume.

Muting the microphone input quickly (Voice Mute)

While calling, activating the Voice Mute function will instantly mute the microphone input. Your voice will not be heard by the caller.

While calling, press ►/II to mute the microphone input.

Press ►/II again will bring the microphone input back to its previous volume level.

Call Switching Operation

While making a call, this function allows you to initiate the transfer of the audio between the mobile phone and the speakers in the car.

While calling, press **BAND** to switch the call sound between the unit and mobile phone.

Note

- Depending on the mobile phone, this operation may not be performed.

BLUETOOTH Audio Operation

Audio information of a BLUETOOTH compatible mobile phone, a portable player, etc., is controllable/playable wirelessly* from this unit.

* To play back audio, a mobile phone or a portable player conforming to A2DP (Advanced Audio Distribution Profile) and AVRCP (Audio/Video Remote Control Profile) is required. Not all functions work with all devices.

Note

- Set "Audio" to ON when you want to use Bluetooth Audio function. Refer to "Setting the BLUETOOTH Connection (Bluetooth IN)" on page 22.
- During a call, sound on the BLUETOOTH audio source is muted.
- If you operate the Hands-free phone (e.g. searching in the phonebook) while using the Bluetooth Audio function, BLUETOOTH Audio playback may be affected.

Recalling the Bluetooth Audio Mode

Press **SOURCE/⏻** to select the Bluetooth Audio mode.

Selecting the desired Song

1 Press ◀◀.

Return the beginning of the song being played back.

2 Press ▶▶.

Forward the next song.

Pressing and holding ◀◀ or ▶▶ will fast backward/fast forward track continuously.

Pausing

Press ▶/||.

A playback stops. Touching again will resume a playback.

USB Memory (optional)

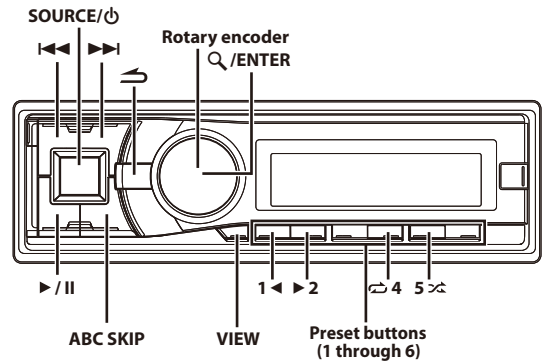

Connecting the USB Memory (optional)

If a USB Memory device is connected to the unit, MP3/WMA/AAC files can be played back.

Note

- In the USB mode, when this unit is reset, ACC is switched from OFF to ON, or when the USB is connected to this unit, "Banking" is displayed for several seconds.

Using the USB Memory Banking Function

What is a Bank?

A bank is a unit of up to 1,000 songs, which is stored in memory. "Banking" refers to the grouping of songs available in USB Memory, in banks of 1,000 songs each. However, when a USB Memory is connected, 1BANK can store up to 1,000 songs under the following conditions. Otherwise, the number of songs that can be stored may be less than 1,000.

Conditions (general estimate values)
Playlists: 20 (32 characters; 64 bytes)
Genres: 10 (32 characters; 64 bytes)
Composers: 30 (32 characters; 64 bytes)
Artists: 30 (32 characters; 64 bytes)
Albums: 100 (32 characters; 64 bytes)
Titles: 1,000 (32 characters; 64 bytes)
Folders: 100 (32 characters; 64 bytes)
Files: 1,000 (32 characters; 64 bytes)
File Paths: 1,000 (128 characters; 256 bytes)

About Banking

While a bank is being built up, "Banking" is displayed. Banking occurs whenever a USB Memory device is connected or after power to the head unit turns on. It can take anywhere from a few seconds to up to several minutes for banking to complete. This depends on the number of files and folders in USB Memory.

Available operations while Banking

- During Banking, the information display changes so the VIEW operation is not available.
- With a song playing, Regular fast-forwarding and next song selection is available.
- While Banking, the song playback order may differ from the song order in the USB Memory device.
- Searching is not recommended during the Banking process as the database is under construction at this time, and malfunction may result in some cases.

This unit has a BANK function that automatically divides every 1,000 songs stored in USB Memory into individual banks to make searching and playing back a song easier. A maximum of 1,000 songs for one bank can be stored according to the order stored in USB Memory. A maximum of 20 banks (20,000 songs) can be recognized.

Bank No.	Song number
Bank 1	1~1,000
Bank 2	1,000~2,000
⋮	⋮
Bank 20	19,001~20,000

About MP3/WMA/AAC File of USB Memory

1 Press **SOURCE/⏻** to select the USB mode.

2 Press **⏮** or **⏭** to select the desired track (file).

Pressing and holding **⏮** or **⏭** will fast backward/fast forward track continuously.

3 To pause playback, press **⏸/||**.

Pressing **⏸/||** again will resume playback

Note

- Any file protected by DRM (Digital Rights Management) copy protection, cannot be played back on this unit.
- The playback time may not be correctly displayed when a VBR (Variable Bit Rate) recorded file is played back.
- If there is tag information, artist name/album name/track name is displayed.
- If an MP3/WMA/AAC file contains ID3 tag/WMA tag information, the ID3 tag/WMA tag information is displayed (e.g., song name, artist name, and album name). All other tag data is ignored.
- If text information is not compatible with this unit, the display is blank.
- Before disconnecting USB Memory, be sure to change to another source or set to pause.
- Press **VIEW** to switch the display. For details, refer to "Displaying the Text" on page 16.

Repeat Play

1 Press **↺4**.

The song is played back repeatedly.

When a song is searched by Tag information.

RPT*1 → RPT **■***2 → RPT **■***3 → (off) → RPT

When a folder/file is searched by (FILE NAME) mode:

RPT*1 → RPT **□***4 → (off) → RPT

- *1 Only a file is repeatedly played back.
- *2 According to the artist information of the current song, a playlist about all the songs with the same artist of the Bank are made into a playlist, which then starts to play back.
- *3 According to the album information of the current song, a playlist about all the songs with the same album of the Bank are made into a playlist, which then starts to play back.
- *4 Only files in a folder are repeatedly played back.

2 To cancel repeat play, select (off) with the above procedure.

Note

- During repeat play, setting M.I.X. to ON will cancel the repeat play.

M.I.X.(Random Play)

1 Press **5** **↺**.

The songs are played back in random sequence.

When a song is searched by Tag information.

MIX*1 → MIX ALL*2 → (off) → MIX

When a folder/file is searched by (FILE NAME) mode:

MIX **□***3 → MIX ALL*4 → (off) → MIX

- *1 Song shuffle randomly plays back songs within a selected category (playlist, album, etc.). The songs within the category are played just once until all songs have been played.
- *2 All songs in the current Bank are played back in random sequence. Any one song does not play back again until all songs have been played back.
- *3 All songs in the current folder are played back in random sequence. Any one song does not play back again until all songs have been played back.
- *4 All songs in the USB Memory are played back in random sequence. Any one song does not play back again until all songs have been played back.

2 To cancel M.I.X. play, select (off) with the above procedure.

Note

- When a song is played back during Random (M.I.X.) play in the USB mode, the song can be played back again randomly even if not all songs in the current Bank have been played back.
- During M.I.X. play, setting repeat play to ON will cancel the M.I.X. play.
- During repeat play, etc., the track number display for M.I.X. play may be incorrect.

Searching for a desired Song

You can select to search a song by Tag information or (FILE NAME) mode. Before you search a song, select your desired search mode in "Setting the USB Search Mode" (refer to "Setting the USB Search Mode" on page 20).

Searching by Tag information

Before performing the following procedures, make sure Tag is selected in "Setting the USB Search Mode" (refer to "Setting the USB Search Mode" on page 20).

A USB Memory Device can contain hundreds of songs. By using file tag information and keeping these songs organized in playlists, this unit's search functions will ease song searches.

Each music category has its own individual hierarchy. Use the Bank*1/Playlists/Artists/Albums/Songs/Genres/Composers/Folders/Files search mode to narrow searches based on the table below.

Hierarchy 1	Hierarchy 2	Hierarchy 3	Hierarchy 4	Hierarchy 5
Bank*1	Playlist	Song	-	-
Bank*1	Artist*	Album*	Song	-
Bank*1	Album*	Song	-	-
Bank*1	Song*	-	-	-
Bank*1	Genre*	Artist*	Album*	Song
Bank*1	Composer*	Album*	Song	-
Bank*1	Folder	File	-	-
Bank*1	File	-	-	-

*1 A maximum of 1,000 songs for one bank can be stored according to the order stored in USB Memory. However, song stored order in bank may differ from the song order in the USB Memory device in some case.

For example:

Searching by Artist name

The following example explains how an Artists search is performed. Another search mode can be used for the same operation, although the hierarchy differs.

- 1 Press **Q/ENTER** to activate the search selection mode.
- 2 Turn the **Rotary encoder** to select a desired Bank, and then press **Q/ENTER**.

The "Banking" may be displayed for a few seconds.

- 3 Turn the **Rotary encoder** to select the Artist search mode, and then press **Q/ENTER**.

Playlist ↔ Artist ↔ Album ↔ Song ↔ Genre ↔ Composer ↔
Folder ↔ File ↔ Playlist

- 4 Turn the **Rotary encoder** to select the desired Artist, and then press **Q/ENTER**.
- 5 Turn the **Rotary encoder** to select an album, and then press **Q/ENTER**.
- 6 Turn the **Rotary encoder** to select a song and press **Q/ENTER**.

The selected song is played back.

Searching by (FILE NAME) mode

Before performing the following procedures, make sure FILE NAME is selected in "Setting the USB Search Mode" (refer to "Setting the USB Search Mode" on page 20).

USB Memory can contain hundreds of songs. By organizing songs by folder, you can quickly find a desired folder/file. This operation is similar to search a folder/file from PC.

- 1 Press **Q/ENTER** to activate the search mode.
- 2 Turn the **Rotary encoder** to select a desired folder/file.
- 3 Press **Q/ENTER** to play the selected file or enter the selected folder.
Press and hold **Q/ENTER** for at least 2 seconds to play back all songs in the selected folder
- 4 If a folder is opened in Step 3, Repeat Steps 2 to 3 until the desired folder/file is found.

Note

- In the Tag search mode, after pressing and holding **Q/ENTER** for at least 2 seconds while in each hierarchy (except Song and File hierarchy), all songs of the selected hierarchy are played back.
- Even if the songs belong to the same playlist, they may be saved in different BANK.
- After selecting [ALL] in the Tag search mode with "*", press and hold **Q/ENTER** for at least 2 seconds to play back all songs in the selected search mode.
- While in the search mode, if you press and hold **↵** for at least 2 seconds, or no operation is performed for 60 seconds, the search mode is cancelled.

- The root folder of USB Memory is displayed as "ROOT".
- When the bank is changed during Repeat play, the Repeat play will be cancelled.
- In the search mode, pressing **↵** will return to the previous mode.
- When search is made during M.I.X. play, the M.I.X. play mode will be cancelled.
- If any one of the **preset buttons (1 through 6)** is pressed in the search mode, a search can be made quickly by skipping to the specified location. For details, refer to "Direct Search Function" on page 29.
- In the Tag search mode, a search can be made quickly by Alphabet search function to find the desired artist or song, etc. For details, refer to "Alphabet search function" on page 30..
- In the (FILE NAME) search mode, a search can be made quickly by USB Skip function to find the desired folder/file. For details, refer to "Setting the USB Skip function" on page 20.
- When searching for a song, artist, etc., in USB Memory, the display order may be incorrect if the character code of the file tag information is mixed.

Direct Search Function

The unit's direct search function can be used to search for an album, song, etc., more efficiently. In Playlist/Artist/Album/Song/Podcast/Genre/Composer mode, you can quickly target any song.

In the search mode, press any one of the preset buttons (1 through 6) to quickly skip over a designated percent of your song content.

Song search example:

If there are 100 songs in your iPod/iPhone, they are divided into 6 groups using percentages (shown below). These groups are assigned to the preset buttons (1 through 6).

Example 1:

Suppose the song you are searching for is located at around the middle (50%) of your library: press button 4 to jump to the 50th song and turn the Rotary encoder to find the desired song.

Example 2:

Suppose the song you are searching for is located near the end (83%) of your library: press button 6 to jump to the 83rd song and turn the **Rotary encoder** to find the desired song.

	All 100 songs (100%)					
	0%	17%	33%	50%	67%	83%
Preset buttons	1	2	3	4	5	6
Songs	1st song	17th song	33rd song	50th song	67th song	83rd song

Note

- This function is inactive during Alphabet Search mode.

Select Playlist/Artist/Album/Genre/Composer/Folder

Playlist/Artist/Album/Genre/Composer/Folder can be easily changed. For example, if you listen to a song from a selected album, the album can be changed.

Press 1 ◀ or ▶ 2 to select the desired Playlist/Artist/Album/Genre/Composer/Folder.

Note

- If the song search mode was used to select a song, this function is inactive.
- If an album is selected during an artist search, other albums by that artist are searchable.
- This function is inactive during shuffle (M.I.X.) playback.
- This function is inactive during RPT ALBUM/RPT ARTIST playback.

Alphabet search function

The unit's alphabet search function can be used to search for an album, song, etc., more efficiently. In Playlist/Artist/Album/Song/Podcast/Genre/Composer search mode, select the first letter of your desired title (album, song, etc.), the titles beginning with this letter are listed. By using this function, you can quickly target any song.

1 In the search mode, press ABC SKIP.

The letter selection list is displayed.

2 Turn the Rotary encoder to select a desired letter (e.g. M), and then press Q/ENTER.

The titles beginning with "M" are listed.

3 Turn the Rotary encoder to select the desired title.

Note

- While in Alphabet search mode, pressing ↵ will return to the previous mode.
- If the Playlist search mode is used to search for a song, the Alphabet search function is inactive in the song search hierarchy.

Search Position Memory

During playback, you can quickly return to the last-selected hierarchy level in the search mode.

Press ↵.

The hierarchy you selected last in the search mode is displayed.

iPod/iPhone (optional)

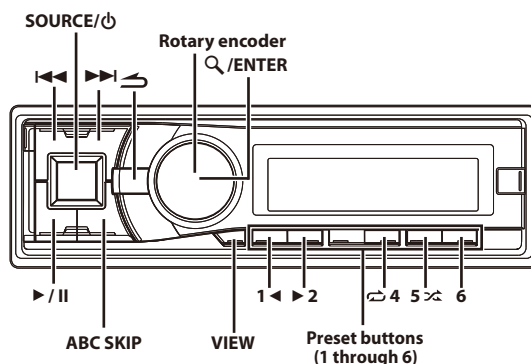

Connecting an iPod/iPhone

An iPod/iPhone can be connected to this unit by using the Interface cable for iPod (supplied). When this unit is connected by using the cable, the controls on the iPod are not functional.

Note

- Internet and telephone functions of the iPod touch or iPhone, etc., can also be used while connected to this unit. Using these functions will stop or pause the currently playing songs. During this time, do not operate the unit to avoid a malfunction.
- If you connect an iPhone to this unit, it can be used as an iPod. If you use iPhone as a hands-free phone, use the unit in which the BLUETOOTH function is built.
- Do not leave an iPod/iPhone in a car, as its mechanism is sensitive to high temperature and humidity conditions, and damage may result.

About iPod/iPhone models usable with this unit

- Confirmed devices regarding Made for iPod. Correct function of earlier versions cannot be guaranteed.
 - iPod touch (4th generation): Ver.4.3
 - iPod nano (6th generation): Ver.1.0.0
 - iPod touch (3rd generation): Ver.4.3
 - iPod nano (5th generation): Ver.1.0.2
 - iPod classic (160 GB) (Late 2009): Ver.2.0.4
 - iPod touch (2nd generation): Ver.4.2.1
 - iPod nano (4th generation): Ver.1.0.4
 - iPod classic (120 GB): Ver.2.0.1
 - iPod touch (1st generation): Ver.3.1.3
 - iPod nano (3rd generation): Ver.1.1.3
 - iPod classic (80 GB, 160 GB): Ver.1.1.2
 - iPod nano (2nd generation): Ver.1.1.3
 - iPod with video: Ver.1.3
 - iPod nano (1st generation): Ver.1.3.1
- Confirmed devices regarding Made for iPhone. Correct function of earlier versions cannot be guaranteed.
 - iPhone 4: Ver.4.2.1
 - iPhone 3GS: Ver.4.3
 - iPhone 3G: Ver.4.2.1
 - iPhone: Ver.3.1.3
- For clarity in identifying your model of iPod, please see Apple's own document "Identifying iPod models" at <http://support.apple.com/kb/HT1353>
- This unit does not support video playback from iPod/iPhone, even using a video-compatible cable.

Playback

1 Press **SOURCE/⏻** to switch to the USB iPod mode

2 Press **⏮** or **⏭** to select the desired song.

Pressing and holding **⏮** or **⏭** will fast backward/fast forward the current track.

3 To pause playback, press **⏸/⏹**.

Pressing **⏸/⏹** again will resume playback.

Note

- A song playing on the iPod/iPhone while it is connected to this unit will continue to play from where it was paused after disconnection.
- If you listen to an episode from a selected Podcast or Audiobook, the episode can be changed by pressing **1** or **2**.
- An episode may have several chapters. The chapter can be changed by pressing **⏮** or **⏭**.

Searching for a desired Song

An iPod/iPhone can contain hundreds of songs. By using file tag information and keeping these songs organised in playlists, this unit's search functions will ease song searches. Each music category has its own individual hierarchy. Use the Playlist/ Artist/Album/Song/Podcast/ Genre/Composer/Audiobook search mode to narrow searches based on the table below.

Hierarchy 1	Hierarchy 2	Hierarchy 3	Hierarchy 4
Playlist	Song	—	—
Artist*	Album*	song	—
Album*	Song	—	—
Song	—	—	—
Podcast	Episode	—	—
Genre*	Artist*	Album*	Song
Composer*	Album*	Song	—
Audiobook	—	—	—

For example:

Searching by Artist name.

The following example explains how an Artist search is performed.

Another search mode can be used for the same operation, although the hierarchy differs.

1 Press **Q/ENTER** to activate the search selection mode.

2 Turn the **Rotary encoder** to select the Artist search mode, and then press **Q/ENTER**.

Playlist ↔ Artist ↔ Album ↔ Song ↔ Podcast ↔ Genre ↔ Composer ↔ Audiobook ↔ Playlist

3 Turn the **Rotary encoder** to select the desired Artist, and then press **Q/ENTER**.

4 Turn the **Rotary encoder** to select the desired Album, and then press **Q/ENTER**.

5 Turn the **Rotary encoder** to select the desired Song, and then press **Q/ENTER**.

The selected song is played back.

Note

- After pressing and holding **Q/ENTER** for at least 2 seconds while in each hierarchy (except Song and Audiobook hierarchy), all songs of the selected hierarchy are played back.
- After selecting [ALL] in the search mode with "*", press and hold **Q/ENTER** for at least 2 seconds to play back all songs in the iPod/iPhone or selected search mode.
- While in the search mode, if you press and hold **↶** for 2 seconds, or no operation is performed for 60 seconds, the search mode is cancelled.
- In the search mode, pressing **↶** will return to the previous mode.
- When search is made during M.I.X. play, the M.I.X. play mode will be cancelled.
- "No Song" will be displayed if there are no songs in the selected playlist in the Playlist search mode.
- "No Podcast" will be displayed if there is no podcast data in the iPod/iPhone in the Podcast search mode.
- "No Audiobook" will be displayed if there is no audiobook data in the iPod/iPhone in the Audiobook search mode.
- If "iPod name" stored in the iPod/iPhone is selected in the desired Playlist search mode, and **Q/ENTER** is pressed, you can search for all songs in the iPod/iPhone. Also, if you press and hold **Q/ENTER** for at least 2 seconds, all songs in the iPod/iPhone are played back.
- Depending on the iPod/iPhone, podcast search is not supported.
- During search mode, a search can be made quickly by Alphabet search function to find the desired artist or song, etc. For details, refer to "Alphabet search function" on page 32.
- If any one of the **preset buttons (1 through 6)** is pressed in the search mode, a search can be made quickly by skipping to the specified location. For details, refer to "Direct Search Function" on page 31.

Direct Search Function

The unit's direct search function can be used to search for an album, song, etc., more efficiently. In Playlist/Artist/Album/Song/Podcast/Genre/Composer/Audiobook mode, you can quickly target any song.

In the search mode, press any one of the preset buttons (1 through 6) to quickly skip over a designated percent of your song content.

Song search example:

If there are 100 songs in your iPod/iPhone, they are divided into 6 groups using percentages (shown below). These groups are assigned to preset buttons 1 through 6.

Example 1:

Suppose the song you are searching for is located at around the middle (50%) of your library: press button 4 to jump to the 50th song and turn the **Rotary encoder** to find the desired song.

Example 2:

Suppose the song you are searching for is located near the end (83%) of your library: press button 6 to jump to the 83rd song and turn the **Rotary encoder** to find the desired song.

	All 100 songs (100%)					
	0%	17%	33%	50%	67%	83%
Preset buttons	1	2	3	4	5	6
Songs	1st song	17th song	33rd song	50th song	67th song	83rd song

Select Playlist/Artist/Album/Genre/ Composer/Episode

Playlist/Artist/Album/Genre/Composer/Episode can be easily changed. For example, if you listen to a song from a selected album, the album can be changed.

Press **1** ◀ or ▶ **2** to select the desired Playlist/Artist/Album/Genre/Composer/Episode.

Note

- If the song search mode was used to select a song, this function is inactive.
- If an album is selected during an artist search, other albums by that artist are searchable.
- This function is inactive during shuffle (M.I.X.) playback.

Alphabet search function

The unit's alphabet search function can be used to search for an album, song, etc., more efficiently. In Playlist/Artist/Album/Song/Podcast/Genre/Composer/Audiobook search mode, select the first letter of your desired title (album, song, etc.), the titles beginning with this letter are listed. By using this function, you can quickly target any song.

1 In the search mode, press ABC SKIP.

The letter selection list is displayed.

2 Turn the Rotary encoder to select a desired letter (e.g. M), and then press Q/ENTER.

The titles beginning with "M" are listed.

3 Turn the Rotary encoder to select the desired title.

Note

- While in Alphabet search mode, pressing ↩ will return to the previous mode.
- If the Playlist search mode is used to search for a song, the Alphabet search function is inactive in the song search hierarchy.

Search Position Memory

During iPod/iPhone playback, you can quickly return to the last-selected hierarchy level in the search mode.

Press ↩.

The hierarchy you selected last in the search mode is displayed.

Random Play Shuffle (M.I.X.)

The Shuffle function of the iPod/iPhone is displayed as M.I.X. on this unit.

Shuffle Albums:



The songs on each album are played back in proper order. Upon completion of all the songs on the album, the next album is selected randomly. This continues until all albums have been played.

Shuffle Songs

Song shuffle randomly plays back songs within a selected category (playlist, album, etc.). The songs within the category are played just once until all songs have been played.

1 Press 5 .

The songs are played back in random sequence.

MIX ^{*1} → MIX^{*2} → (off) → MIX 

*1 Shuffle Albums.

*2 Shuffle Songs.

2 To cancel M.I.X. play, select (off) with the above procedure.

Note

- If a song is selected in the album search mode before selecting M.I.X. play, the songs will not play back randomly even when Shuffle Albums is selected.

Shuffle ALL:

Shuffle ALL plays all songs in the iPod/iPhone randomly. Any one song does not play back again until all songs have been played back.

1 Press 6.

The songs are played back in random sequence.

MIX ALL^{*} → (off) → MIX ALL

* Shuffle ALL.

2 To cancel M.I.X. play, select (off) with the above procedure.

Note

- If Shuffle ALL is selected, the selected songs being played back in the search mode are cancelled.

Repeat Play

Only Repeat One is available for the iPod/iPhone.

Repeat One:

A single song is repeatedly played back.

1 Press 4.

The song is played back repeatedly.

RPT^{*} → (off) → RPT

* Repeat One.

2 To cancel repeat play, select (off) with the above procedure.

Note

- Depending on the connected iPod, track up/down may be not available during Repeat play.

Displaying the Text

You can display the tag information of a song in the iPod/iPhone.

Press **VIEW**.

Each press changes the display.

Note

- When the Text Scroll is set to Manual, press and hold **VIEW** for at least 2 seconds, the current text will be scrolled one time.

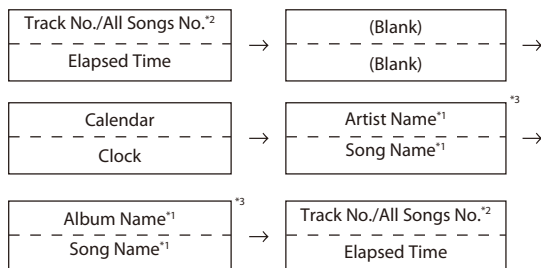

*1 TAG information

If the Text Scroll (refer to "Scroll Setting (Text Scroll)" on page 20) is set to "Auto," the tag information will scroll automatically.

If there is no text information, nothing will be displayed.

- *2 The numbers of all songs displayed vary depending on the songs selected by the search.

- *3 When the Text Scroll (refer to "Scroll Setting (Text Scroll)" on page 20) is set to "Auto," the display cannot be switched by pressing **VIEW**. The display contents switch alternately.

Note

- Only alphanumeric characters (ASCII) can be displayed.
- The maximum number of characters for the head unit is 128 (128 byte).
- Some characters may not be correctly displayed.
- The display is blank when text information is not compatible with this unit.

IMPRINT Operation (optional)

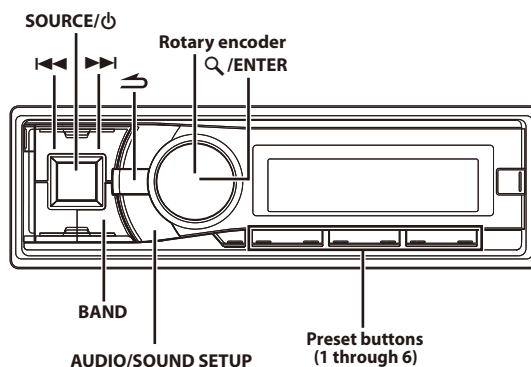

Alpine introduces IMPRINT - the world's first technology that thoroughly eliminates in-car acoustic problems that normally degrade sound quality, which enables us to experience music the way the artist intended.

When the IMPRINT audio processor (PXA-H100) (sold separately) is connected to this unit, MultEQ and the following sound adjustment can be performed.

Changing MultEQ mode

MultEQ, developed by Audyssey Labs, automatically corrects the audio for the listening environment. The system is optimized for selected positions in the vehicle. To accomplish this, MultEQ must take measurements of the vehicles response characteristics. For details on the set up procedure, consult your authorized Alpine dealer.

- Press and hold **SOUND SETUP** for at Least 2 seconds to activate the Sound menu selection mode.
- Turn the **Rotary encoder** to select MultEQ Mode, and then press **Q/ENTER**.
- Turn the **Rotary encoder** to select the desired MultEQ mode, and then press **Q/ENTER**.

OFF (Manual Mode) ↔ Curve 1 (MultEQ-1) ↔ Curve 2 (MultEQ-2)

Note

- The Curve mode can be selected only when Curve 1 and Curve 2 are stored.
- When using MultEQ, MX, X-Over, T.Correction, Factory's EQ, SUBW. Phase, SUBW. Channel, TW Setup, EQ Mode, Filter Type and Parametric EQ/Graphic EQ are set automatically. They are no longer user adjustable.
- When an external audio processor is connected, the MultEQ function cannot be used.

Adjusting Subwoofer Level/Bass Level/ Treble Level/Fader (Between Front and Rear)/Balance (Between Left and Right)/ Black Out in MultEQ mode

You can change these settings to create your own preference in MultEQ (Curve 1 or Curve 2) mode.

1 Press **AUDIO** repeatedly to select the MultEQ adjustment item.

SUBWOOFER*¹ → BASS*² → TREBLE*² → BALANCE → FADER*³ → BLACK OUT*⁴ → DEFEAT → VOLUME → SUBWOOFER

*1 When the SUBWOOFER mode is set to OFF, its level cannot be adjusted.

*2 This function is inoperable when MultEQ is set to OFF.

*3 If you set the 2.2ch (3WAY)/4.2ch (FRONT/REAR/SUBW.) switch of the IMPRINT audio processor (PXA-H100) to 2.2ch (3WAY), you cannot adjust the FADER mode. For details, refer to the Owner's Manual of PXA-H100.

*4 When BLACK OUT mode is turned ON, all display indications on this unit will turn off to reduce power consumption. This additional power enhances the sound quality. If any button on the unit is pressed during the Blackout Mode, the function is displayed for 5 seconds before returning to Blackout mode.

Note

- If no operation is performed for 5 seconds after selecting the SUBWOOFER, BASS, TREBLE, FADER, BALANCE, BLACK OUT or DEFEAT mode the unit automatically returns to normal mode.

2 Turn the Rotary encoder to change the setting as below.

Subwoofer level	0 ~ 15
Bass level	-7 ~ +7
Treble level	-7 ~ +7
Balance	-15(L) ~ 15(R)
Fader	-15(R) ~ 15(F)
Black Out	ON/OFF
Defeat	ON/OFF
Volume	0 ~ 35

Note

- Depending on the connected devices, some functions and display indications do not work.

Adjusting Sound Setting in Manual Mode

You can change these sound settings to create your own preference when the MultEQ mode is set to Mult EQ OFF (Manual Mode).

Use steps 1 to 4 to select one of the Sound menu modes to modify. See the applicable section below for details about the selected item.

1 Press and hold **SOUND SETUP** for at Least 2 seconds to activate the Sound menu selection mode.

2 Turn the Rotary encoder to select the desired item, and then press **Q/ENTER**.

MultEQ Mode ↔ Subwoofer ↔ SUBW. System*¹ ↔ SUBW. Phase*¹ ↔ SUBW. Channel*¹ ↔ Factory's EQ ↔ TW Setup*² ↔ Filter Type ↔ Media Xpander ↔ MX Level*³ ↔ EQ Mode ↔ TCR Parameter ↔ Sound Field*⁴ ↔ MultEQ Mode
(e.g. Select Subwoofer)

*1 These functions are inoperable when Subwoofer is set to OFF.

*2 This function can be operable only when PXA-H100 (sold separately) is connected and 2.2ch (3WAY) mode is set. For details, refer to the Owner's Manual of PXA-H100.

*3 This function is inoperable when Media Xpander is set to OFF.

*4 In step 2, three sound adjustment items (Parametric EQ/ Graphic EQ, T.Correction, X-Over) can be selected in Sound Field Adjustment mode, turn the **Rotary encoder** to select the desired item, and then press **Q/ENTER** to continue to step 3.

3 Turn the Rotary encoder to change the setting, and then press **Q/ENTER**.

(e.g. Select Subwoofer ON or Subwoofer OFF)

4 Press and hold **↶** for at least 2 seconds to return to normal mode.

Note

- Media Xpander, Factory's EQ, Parametric EQ/Graphic EQ, EQ Mode and MX Level Adjustment are inoperable when DEFEAT is set to ON.
- Pressing **↶** returns to the previous Sound menu mode.
- If no operation is performed for 60 seconds, Sound menu mode is cancelled.

Turning Subwoofer ON/OFF

When the subwoofer is on, you can adjust the subwoofer output level.

Setting item: Subwoofer

Setting contents:

ON (Initial setting) / OFF

ON:

The subwoofer signal is output from the Subwoofer RCA Connectors (refer to "Connections" on page 50)

OFF:

No subwoofer signal is output from the Subwoofer RCA Connectors (refer to "Connections" on page 50).

Setting the Subwoofer System

When the subwoofer is on, you can select either System 1 or System 2 for the desired subwoofer effect.

Setting item: SUBW. System

Setting contents:

1 (Initial setting) / 2

- 1:
Subwoofer level changes according to the main volume setting.
- 2:
Subwoofer level change is different from the main volume setting.
For example, even at low volume settings, the subwoofer is still audible.

Setting the Subwoofer Phase

The subwoofer output phase is toggled SUBWOOFER NORMAL (0°) or SUBWOOFER REVERSE (180°). To adjust the level, turn the **Rotary encoder**.

■ **Setting item:** SUBW. Phase

Setting contents:

PHASE 0° (Initial setting) / PHASE 180°

Setting the Subwoofer Channel (SUBW. Channel)

You can set the subwoofer output to stereo or monaural. Make sure to set the correct output for your subwoofer type.

■ **Setting item:** SUBW. Channel

Setting contents:

STEREO (Initial setting) / MONO

STEREO:

Subwoofer stereo (L/R) output

MONO:

Subwoofer monaural output

Equalizer Presets (Factory's EQ)

10 typical equalizer settings are preset at the factory for a variety of musical source material.

Flat ↔ Pops ↔ Rock ↔ News ↔ Jazz&Blues ↔ Electrical Dance
↔ Hip Hop&Rap ↔ Easy Listening ↔ Country ↔ Classical ↔
User1 ↔ User2 ↔ User3 ↔ User4 ↔ User5 ↔ User6

Note

- By selecting User's 1 to 6, you can recall the stored preset number (refer to "Adjusting the Graphic Equalizer Curve" on page 14 or refer to "Adjusting the Parametric Equalizer Curve" on page 14).

Setting the Response Slope for the High Range Speaker (TW Setup)

Setting the response characteristic of tweeter to FLAT in 2.2ch (3WAY) mode could damage the speaker. Make sure the Crossover cut-off is appropriate for the tweeter being used (Refer to "Adjusting the Crossover Settings" on page 36).

■ **Setting item:** TW Setup

Setting contents:

FACTORY'S (Initial setting) / USER'S

FACTORY'S:

As protection from possible speaker damage, FLAT cannot be set for the response slope of the high range speaker in 2.2ch (3WAY) mode.

USER'S:

The FLAT setting is possible in 2.2ch (3WAY) mode.

Setting the Filter type

■ **Setting item:** Filter Type

Setting contents:

NORMAL (Initial setting) / INDIVIDUAL

NORMAL (L=R):

Left and right speakers are adjusted equally.

INDIVIDUAL (L/R):

Left and right speakers are individually adjusted.

Turning Media Xpander ON/OFF

When the Media Xpander is on, you can adjust the Media Xpander level (refer to "Setting the MX Level" on page 35).

■ **Setting item:** Media Xpander

Setting contents:

OFF (Initial setting) / ON

Setting the MX Level

MX (Media Xpander) makes vocals or instruments sound distinct regardless of the music source. The CD, USB Memory and iPod/iPhone, will be able to reproduce the music clearly even in cars with a lot of road noise.

Changing the source to which you want to apply Media Xpander.

FM (MX level 1 to 3):

The medium to high frequencies become clearer, and produces well balanced sound at all frequencies.

CD (MX level 1 to 3):

CD mode processes a large amount of data during playback. MX takes advantage of this large data quantity to reproduce a more clear, clean output.

CMPM (MX level 1 to 3):

This corrects information that was lost at the time of compression. This reproduces a well-balanced sound close to the original.

DVD (Video CD) (MOVIE MX level 1 to 2):

The dialogue portion of a video is reproduced more clearly.

(DVD MUSIC):

A DVD or Video CD contains a large quantity of data such as music clip. MX uses this data to reproduce the sound accurately.

AUX (MX level 1):

Choose the MX mode (CMPM, MOVIE, or MUSIC) that corresponds to the media connected.

Note

- Each music source, such as CD and MP3/WMA/AAC can have its own MX setting.
- On disks with both MP3/WMA/AAC and CD-DA, when the source changes from "MP3/WMA/AAC to CD-DA" or "CD-DA to MP3/WMA/AAC", MX-mode switching may delay playback slightly.
- Setting to Non Effect sets MX mode of each music source to OFF.
- The function is inoperable when DEFEAT is set to ON.
- There is no MX mode for AM radio.
- If an audio processor with the MX function (PXA-H701, etc.) is connected, its own MX processing is applied to the music source. Since the processor MX settings may not match the head unit, the audio processor needs to be adjusted. For details, refer to the Owner's Manual of the audio processor.
- "CMPM" is applied for MP3/WMA/AAC and iPod/iPhone.

Setting EQ mode

This setting gives you a choice of 5-band parametric, or 7-band graphic equalizer.

Setting item: EQ Mode

Setting contents:

Parametric EQ (Initial setting) / Graphic EQ

PEQ:

5-band Parametric EQ.

GEQ:

7-band Graphic EQ

Setting the Time Correction Unit (TCR Parameter)

You can change the unit, (cm or inch) of time correction.

Setting item: TCR Parameter

Setting contents:

cm (Initial setting) / inch

Sound Field Adjustment

The setting of Parametric EQ/Graphic EQ, Time Correction and X-Over can be adjusted in this mode.

Adjusting the Parametric Equalizer Curve

You can modify the Equalizer settings to create a response curve more appealing to your personal taste. To adjust the Parametric Equalizer Curve, set the EQ Mode to Parametric EQ. For details, refer to "Setting EQ mode" on page 14.

1 After selecting Parametric EQ from the Sound Field Adjustment mode, press BAND to select the band to be adjusted.

Band 1 → Band 2 → Band 3 → Band 4 → Band 5 → Band 1

2 Press ◀◀ or ▶▶ to select frequency bands.

Adjustable frequency bands: 20 Hz to 20 kHz (in 1/3 octave steps)

Band-1	20 Hz~80 Hz (63 Hz)
Band-2	50 Hz~200 Hz (150 Hz)
Band-3	125 Hz~3.2 kHz (400 Hz)
Band-4	315 Hz~8 kHz (1 kHz)
Band-5	800 Hz~20 kHz (2.5 kHz)

3 Turn the Rotary encoder to adjust the level.

Adjustable level: -6 to +6 dB

4 Press SOURCE/⏻ to set the bandwidth (Q).

Adjustable bandwidth: 1, 1.5, 3

5 To adjust another band, repeat steps 1 to 4 and adjust all bands.

Note

- The frequencies of adjacent bands cannot be adjusted within 4 steps.
- While adjusting the Parametric EQ, you should consider the frequency response of the connected speakers.

Adjusting the Graphic Equalizer Curve

You can modify the equalizer settings to create a response curve more appealing to your personal taste. To adjust the Graphic Equalizer Curve, set the EQ Mode to Graphic EQ. For details, refer to "Setting EQ mode" on page 14.

1 After selecting Graphic EQ from the Sound Field Adjustment mode, press BAND to select the band to be adjusted.

Band 1 → Band 2 → Band 3 → Band 4 → Band 5 → Band 6 → Band 7 → Band 1

2 Turn the Rotary encoder to adjust the level.

Adjustable output level: -6 to +6 dB

3 To adjust another band, repeat steps 1 and 2, and then adjust all bands.

Adjusting the Time Correction

Before performing the following procedures, refer to "About Time Correction" on page 38.

1 After selecting T.Correction from the Sound Field Adjustment mode, press BAND to select a speaker to be adjusted.

2.2ch (3WAY) System

F-L*1 → F-R*2 → R-L*3 → R-R*4 → SW-L → SW-R → F-L

*1 Mid-L (Initial setting)

*2 Mid-R

*3 High-L

*4 High-R

4.2ch (FRONT/REAR/SUBW.) System

F-L*1 → F-R*2 → R-L*3 → R-R*4 → SW-L → SW-R → F-L

*1 Front-L (Initial setting)

*2 Front-R

*3 Rear-L

*4 Rear-R

2 Turn the Rotary encoder to adjust the distance correction value (0.0 to 336.6cm).

L = (distance to farthest speaker) - (distance to other speakers)

3 Repeat steps 1 and 2 to set another speaker.

By setting these values to make its sound reach the listening position at the same time as the sound of other speakers.

Adjusting the Crossover Settings

Before performing the following procedures, refer to "About the Crossover" on page 39.

2.2ch (3WAY) System

1 After selecting X-Over from the Sound Field Adjustment mode, press BAND to select the band to be adjusted.

NORMAL (L=R)

■ **Setting item:** LOW / MID-L / MID-H / HIGH

INDIVIDUAL (L/R)

■ **Setting item:** LOW-L / LOW-R / MID-L-L / MID-L-R / MID-H-L / MID-H-R / HIGH-L / HIGH-R

2 Press ◀◀ or ▶▶ to select the desired cut-off frequency (Crossover Point).

Adjustable frequency bands:

LOW / MID-L	20 Hz~200 Hz
MID-H	20 Hz~20 kHz
HIGH	(1 kHz~20 kHz) ^{*1} / (20 Hz~20 kHz) ^{*2}

*1 When FACTORY'S is selected, refer to "Setting the Response Slope for the High Range Speaker (TW Setup)" on page 35.

*2 When USER'S is selected, refer to "Setting the Response Slope for the High Range Speaker (TW Setup)" on page 35.

3 Press SOURCE/⏻ to adjust the slope.

Adjustable slope: FLAT*, 6 dB/oct., 12 dB/oct., 18 dB/oct., 24 dB/oct.

* FLAT can be set for the HIGH slope only when TW Setup is set to USER'S (refer to "Setting the Response Slope for the High Range Speaker (TW Setup)" on page 35). Depending on the response characteristics of the speaker, care should be taken when setting the response slope to FLAT, as speaker damage may result. With this unit, a message is displayed when the response slope for the high range speaker is set to FLAT.

4 Turn the Rotary encoder to adjust the output level.

Adjustable output level: -12 to 0 dB

5 Repeat steps 1 to 4 to make adjustment to the other bands.

4.2ch (FRONT/REAR/SUBW.) System

1 After selecting X-Over from the Sound Field Adjustment mode, press BAND to select the band to be adjusted.

NORMAL (L=R)

■ **Setting item:** LOW (SUB-W) / MID (REAR) / HIGH (FRONT)

INDIVIDUAL (L/R)

■ **Setting item:** LOW (SUB-W)-L / LOW (SUB-W)-R / MID (REAR)-L / MID (REAR)-R / HIGH (FRONT)-L / HIGH (FRONT)-R

2 Press ◀◀ or ▶▶ to select the desired cut-off frequency (Crossover Point).

Adjustable frequency bands: 20 Hz~200 Hz

3 Press SOURCE/⏻ to adjust the slope.

Adjustable slope: FLAT, 6 dB/oct., 12 dB/oct., 18 dB/oct., 24 dB/oct.

4 Turn the Rotary encoder to adjust the output level.

Adjustable output level: -12 to 0 dB.

5 Repeat steps 1 to 4 to make adjustment to the other bands.

Note

- While adjusting the X-Over, you should consider the frequency response of the connected speakers.
- About the 2.2ch (3WAY)/4.2ch (FRONT/REAR/SUBW.) system, you can switch to 2.2ch (3WAY)/4.2ch (FRONT/REAR/SUBW.) system mode with the 2.2ch (3WAY)/4.2ch (FRONT/REAR/SUBW.) switch on the PXA-H100. For details, refer to the Owner's Manual of PXA-H100.

Storing the Sound Field Adjustment Settings

The Sound Field Adjustment Settings containing Parametric EQ/Graphic EQ, T.Correction and X-Over settings can be stored in the preset memory.

1 When the settings of Sound Field Adjustment have been completed, select any one of the preset buttons (1 through 6) in any item of the Sound Field Adjustment mode (e.g. X-Over), press and hold the desired preset buttons for at least 2 seconds.

2 Turn the Rotary encoder to select Protect YES/NO, and then press Q/ENTER to store the adjusted contents.

Protect YES (Initial setting) ↔ Protect NO

Note

- If YES is selected, the adjusted contents are protected and stored into the preset buttons. When you want to store the parameter into a protected preset button, "Replace NO/YES" can be selected.
- If NO is selected, the preset is stored.
- While performing this operation, all adjusted contents of Parametric EQ/Graphic EQ, T.Correction and X-Over will be stored in the preset buttons.
- The stored contents are not deleted even when resetting the unit or disconnecting the battery.
- The stored contents can be recalled by performing operation (refer to "Recalling the Stored Sound Field Adjustment Settings" on page 15).

Recalling the Stored Sound Field Adjustment Settings

The stored Sound Field Adjustment Settings contain Parametric EQ/Graphic EQ, T.Correction and X-Over settings that are stored in the preset memory.

1 After selecting any item of the Sound Field Adjustment mode (e.g. X-Over), press any one of the preset buttons (1 through 6) that has your desired characteristic in memory to recall the stored settings.

2 Press the preset buttons (1 through 6) again to return to the Sound Field Adjustment mode.

Note

- While performing this operation, all adjustment contents of Parametric EQ/Graphic EQ, T.Correction and X-Over stored in the preset buttons will be recalled.

About Time Correction

The distance between the listener and the speakers in a car vary widely due to the complex speaker placement. This difference in the distances from the speakers to the listener creates a shift in the sounds image and frequency characteristics. This is caused by the time delay between the sound reaching the listener's right versus the left ear. To correct this, this unit is able to delay the audio signal to the speakers closest to the listener. This effectively creates a perception of increased distance for those speakers. The listener can be placed at an equal distance between the left and right speakers for optimum staging. The adjustment will be made for each speaker in 3.4cm steps.

Listening Position example as follows:

Example 1: Front Left Seat

Adjust the time correction level of the front left speaker to a high value and the rear right to zero or a low value.

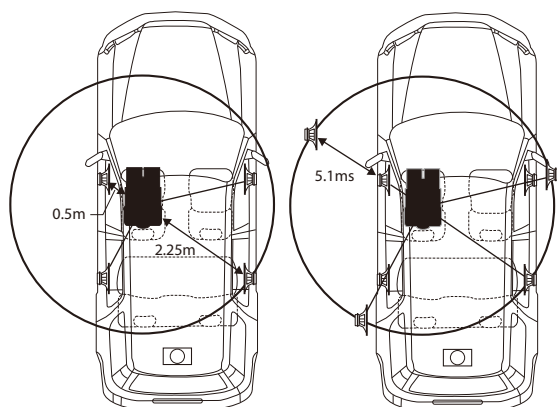

The sound is not balanced because the distance between the listening position and the various speakers is different. The difference in distance between the front left speaker and the rear right speaker is 1.75 m (68-7/8"). Here we calculate the time correction value for the front left speaker in the diagram on the above.

Conditions:

Farthest Speaker - listening position : 2.25 m (88-9/16")
 Front left speaker - listening position : 0.5 m (19-11/16")
 Calculation:
 $L = 2.25 \text{ m} - 0.5 \text{ m} = 1.75 \text{ m} (68-7/8")$
 Time correction = $1.75 \div 343^{*1} \times 1000 = 5.1 \text{ (ms)}$

*1 Speed of sound: 343 m/s (765 mph) at 20°C

In other words, giving the front left speaker a time correction value of 5.1 ms makes it seem as if its distance from the listener is the same as the distance to the farthest speaker. Time correction eliminates the differences in the time required for the sound to reach the listening position. The time of the front left speaker is corrected by 5.1 ms so that its sound reaches the listening position at the same time as the sound of other speakers.

Example 2: All Seats

Adjust the time correction level of each speaker to almost the same level.

- 1 Sit in the listening position (driver's seat, etc.) and measure the distance (in meters) between your head and the various speakers.

- 2 Calculate the difference between the distance correction value to the farthest speaker and the other speakers.

$L = (\text{distance to farthest speaker}) - (\text{distance to other speakers})$ These values are the time correction values for the different speakers. Setting these values to make each sound reach the listening position at the same time as the sound of other speakers.

Time Correction Value List

Delay Number	Time Difference (ms)	Distance (cm)	Distance (inch)
0	0.0	0.0	0.0
1	0.1	3.4	1.3
2	0.2	6.8	2.7
3	0.3	10.2	4.0
4	0.4	13.6	5.4
5	0.5	17.0	6.7
6	0.6	20.4	8.0
7	0.7	23.8	9.4
8	0.8	27.2	10.7
9	0.9	30.6	12.1
10	1.0	34.0	13.4
11	1.1	37.4	14.7
12	1.2	40.8	16.1
13	1.3	44.2	17.4
14	1.4	47.6	18.8
15	1.5	51.0	20.1
16	1.6	54.4	21.4
17	1.7	57.8	22.8
18	1.8	61.2	24.1
19	1.9	64.6	25.5
20	2.0	68.0	26.8
21	2.1	71.4	28.1
22	2.2	74.8	29.5
23	2.3	78.2	30.8
24	2.4	81.6	32.2
25	2.5	85.0	33.5
26	2.6	88.4	34.8
27	2.7	91.8	36.2
28	2.8	95.2	37.5
29	2.9	98.6	38.9
30	3.0	102.0	40.2
31	3.1	105.4	41.5
32	3.2	108.8	42.9
33	3.3	112.2	44.2
34	3.4	115.6	45.6
35	3.5	119.0	46.9
36	3.6	122.4	48.2
37	3.7	125.8	49.6
38	3.8	129.2	50.9
39	3.9	132.6	52.3
40	4.0	136.0	53.6
41	4.1	139.4	54.9
42	4.2	142.8	56.3
43	4.3	146.2	57.6

Delay Number	Time Difference (ms)	Distance (cm)	Distance (inch)
44	4.4	149.6	59.0
45	4.5	153.0	60.3
46	4.6	156.4	61.6
47	4.7	159.8	63.0
48	4.8	163.2	64.3
49	4.9	166.6	65.7
50	5.0	170.0	67.0
51	5.1	173.4	68.3
52	5.2	176.8	69.7
53	5.3	180.2	71.0
54	5.4	183.6	72.4
55	5.5	187.0	73.7
56	5.6	190.4	75.0
57	5.7	193.8	76.4
58	5.8	197.2	77.7
59	5.9	200.6	79.1
60	6.0	204.0	80.4
61	6.1	207.4	81.7
62	6.2	210.8	83.1
63	6.3	214.2	84.4
64	6.4	217.6	85.8
65	6.5	221.0	87.1
66	6.6	224.4	88.4
67	6.7	227.8	89.8
68	6.8	231.2	91.1
69	6.9	234.6	92.5
70	7.0	238.0	93.8
71	7.1	241.4	95.1
72	7.2	244.8	96.5
73	7.3	248.2	97.8
74	7.4	251.6	99.2
75	7.5	255.0	100.5
76	7.6	258.4	101.8
77	7.7	261.8	103.2
78	7.8	265.2	104.5
79	7.9	268.6	105.9
80	8.0	272.0	107.2
81	8.1	275.4	108.5
82	8.2	278.8	109.9
83	8.3	282.2	111.2
84	8.4	285.6	112.6
85	8.5	289.0	113.9
86	8.6	292.4	115.2
87	8.7	295.8	116.6
88	8.8	299.2	117.9
89	8.9	302.6	119.3
90	9.0	306.0	120.6
91	9.1	309.4	121.9
92	9.2	312.8	123.3
93	9.3	316.2	124.6
94	9.4	319.6	126.0

Delay Number	Time Difference (ms)	Distance (cm)	Distance (inch)
95	9.5	323.0	127.3
96	9.6	326.4	128.6
97	9.7	329.8	130.0
98	9.8	333.2	131.3
99	9.9	336.6	132.7

About Time Crossover

Crossover (X-OVER):

This unit is equipped with an active crossover. The crossover limits the frequencies delivered to the outputs. Each channel is controlled independently. Thus, each speaker pair can be driven by the frequencies for which they have been optimally designed. The crossover adjusts the HPF (high pass filter) or LPF (low pass filter) of each band, and also the slope (how fast the filter rolls off the highs or lows).

Adjustments should be made according to the reproduction characteristics of the speakers. Depending on the speakers, a passive network may not be necessary. If you are unsure about this point, consult your authorized Alpine dealer.

4.2ch (FRONT/REAR/SUBW.) mode

	Cut-off frequency (1/3 octave steps)		Slope		Level
	HPF	LPF	HPF	LPF	
Low range speaker	----	20 Hz - 200 Hz	----	FLAT, 6, 12, 18, 24 dB/oct.	0 to -12 dB
Rear high range speaker	20 Hz - 200 Hz	----	FLAT, 6, 12, 18, 24 dB/oct.	----	0 to -12 dB
Front high range speaker	20 Hz - 200 Hz	----	FLAT, 6, 12, 18, 24 dB/oct.	----	0 to -12 dB

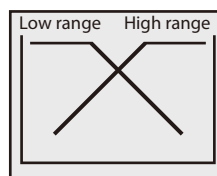

(Different from actual display)

2.2ch (3WAY) mode

	Cut-off frequency (1/3 octave steps)		Slope		Level
	HPF	LPF	HPF	LPF	
Low range speaker	----	20 Hz - 200 Hz	----	FLAT, 6, 12, 18, 24 dB/oct.	0 to -12 dB
Rear high range speaker	20 Hz - 200 Hz	----	FLAT, 6, 12, 18, 24 dB/oct.	----	0 to -12 dB
Front high range speaker	20 Hz - 200 Hz	----	FLAT, 6, 12, 18, 24 dB/oct.	----	0 to -12 dB

* Only when TW Setup is set to USER'S (refer to "Setting the Response Slope for the High Range Speaker (TW Setup)" on page 38).

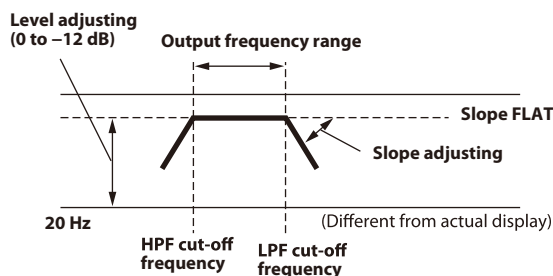
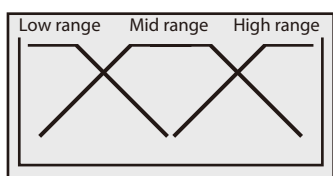

Note

- **HPF (high pass filter):** Cuts the lower frequencies and allows the higher frequencies to pass.
- **LPF (low pass filter):** Cuts the higher frequencies and allows the lower frequencies to pass.
- **Slope:** The level change (in dB) for a frequency change of one octave.
- The higher the slope value, the steeper the slope becomes.
- Adjust the slope to FLAT to bypass the HP or LP filters.
- Do not use a tweeter without the HPF on or set to a low frequency, as it may cause damage to the speaker due to the low frequency content.
- You cannot adjust the crossover frequency higher than the HPF or lower than the LPF.
- Adjustment should be made according to the recommended crossover frequency of the connected speakers. Determine the recommended crossover frequency of the speakers. Adjusting to a frequency range outside that recommended may cause damage to the speakers. For the recommended crossover frequencies of Alpine speakers, refer to the respective Owner's Manual. We are not responsible for damage or malfunction of speakers caused by using the crossover outside the recommended value.

Changer (optional)

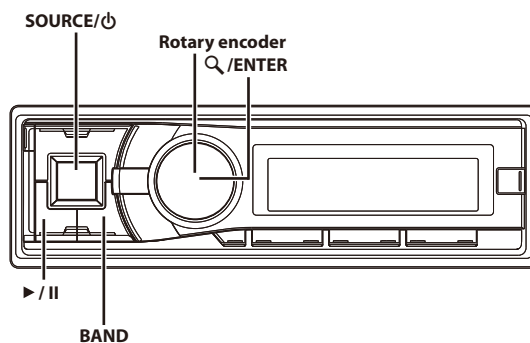

Controlling CD Changer (optional)

An optional 6-disc or 12-disc CD Changer may be connected to this unit if it is Ai-NET compatible. With a CD Changer connected to the Ai-NET input of this unit, the CD Changer will be controllable from this unit. Using the KCA-400C (Multi-Changer Switching device) or the KCA-410C (Versatile Link Terminal) multiple changers can be controlled by this unit.

Refer to "Multi-Changer Selection (optional)" on page 41 for selecting the CD Changers.

Note

- The controls on this unit for CD Changer operation are operative only when a CD Changer is connected.
- The DVD changer (optional) is controllable from this unit as well as the CD changer.
- Depending on the connected DVD Changer, some functions may not be available.

1 Press SOURCE/⏻ to activate the CHANGER mode.

The display shows the disc number and track number.

Note

- The source indicator varies depending on the connected source.
- Press **BAND** to switch the Disc mode in the Changer mode.

2 Press Q/ENTER to activate the search select mode.

3 Turn the Rotary encoder to select the Disc Search, and then press Q/ENTER.

4 Turn the Rotary encoder to select the desired disc in the CD Changer.



The selected disc number appears in the display and CD/MP3 playback starts.

Note

- After selecting the desired disc, you can operate in the same way as for the CD player of this unit. For details, see the CD/MP3/WMA/AAC section.

Playing MP3 Files with the CD Changer (optional)

If you connect a changer compatible with MP3, you can play CD-ROMs, CD-Rs, and CD-RWs containing MP3 files on this unit.

- 1 Press **SOURCE**/ to switch to the **CHANGER** mode.
- 2 Press /**ENTER** to activate the search select mode.
- 3 Turn the **Rotary encoder** to select the Disc Search, and then press /**ENTER**.
- 4 Turn the **Rotary encoder** to select the desired disc in the CD Changer.
- 5 To pause playback, press **▶/||**.

Pressing **▶/||** again will resume playback.

Note

- The unit can play discs containing both audio data and MP3 data.
- For operating MP3 with an MP3 compatible CD Changer, refer to "CD/MP3/WMA/AAC" on page 9.

Multi-Changer Selection (optional)

Alpine's Ai-NET system will support up to 6 CD Changers. When operating two or more changers, the KCA-400C (Multi-Changer Switching device) must be used. If you use 1 Switching device, you can connect up to 4 CD Changers. If you use 2 Switching devices, you can connect up to 6 CD Changers. When using KCA-410C (Versatile Link Terminal), you can connect two changers and two external outputs (AUX).

- 1 Press **SOURCE**/ on this unit to activate the **CHANGER** mode.

Alternatively, press **SOURCE** on the remote control (RUE-4202) to activate the **CHANGER** mode.

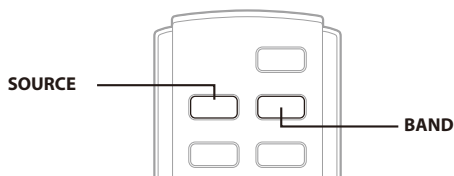

- 2 Press **BAND** to activate the **CD Changer Selection** mode.

The CD Changer Selection mode remains active for several seconds.

- 3 Press **BAND** until the desired CD Changer indicator appears on the display.

Note

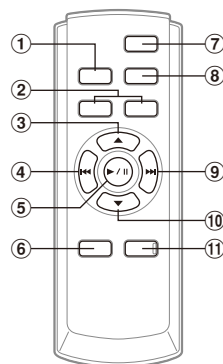

- If the selected CD Changer is not connected, the display will show "NO CHANGER-(No.)."
- To operate the selected changer, refer to "CD/MP3/WMA/AAC" on page 9.
- For further details about the external input (AUX) when using KCA-410C, refer to "Setting the AUX Mode (V-Link)" on page 18.

Remote Control



Controls on Remote Control

- ① **Source Button**
Press this button to select the audio source.

- ② **Volume Adjustment Buttons**
To increase the volume level:
Press the 
To decrease the volume level:
Press the 

- ③ **▲ Button**

Radio mode:

Pressing this button will select, in ascending order, stations programmed into the radio's presets as shown below.

 →  ...  → 

CD Changer mode:

DISC Select (UP) button. Press this button to select a disc in ascending order.

MP3/WMA/AAC mode:

Folder Select (UP) button.
Press this button to select the folder.

MP3 compatible CD changer mode:

Folder Select (UP) / DISC Select (UP) button. Press this button to select a folder in ascending order. Press and hold this button to select a disc in ascending order.

iPod mode:

Switches Playlist/Artist/Album/Genre/Composer.

- ④ **◀◀ DN Button**

Radio mode:

SEEK (DN) Button.

CD/iPod mode:

Press this button to go back to the beginning of the current track.

⑤ **▶/|| Button**

Press this button to switch between the Play and Pause modes for CD.

⑥ **Audio Processor Button**

Each press of the button changes the audio processor mode. For details, refer to "Operating the Audio Processor" as shown below. Press the button to activate the external audio processor mode when the external audio processor is connected.*

* For the operation of external audio processor, refer to the Owner's Manual of the external audio processor you purchased. When the IMPRINT audio processor (PXA-H100) (sold separately) is connected, refer to "IMPRINT Operation (optional)" on page 33.

⑦ **Power Button**

Press this button to turn the power on/off.

⑧ **Band Button**

Radio mode:

BAND Button.

Press this button and the band will change.

Changer mode:

To switch the changer.

⑨ **▶▶ UP Button**

Radio mode:

SEEK (UP) button

CD/iPod mode:

Press this button to advance to the beginning of the next track.

⑩ **▼ Button**

Radio mode:

Pressing this button will select, in descending order, stations programmed into the radio's presets as shown below.

[6] → [5] ... [1] → [6]

CD Changer mode:

DISC Select (DN) button.

Press this button to select a disc in descending order.

MP3/WMA/AAC mode:

Folder Select (DN) button.

Press this button to select the folder.

MP3 compatible CD changer mode:

Folder Select (DN) / DISC Select (DN) button. Press this button to select a folder in descending order. Press and hold this button to select a disc in descending order.

iPod mode:

Switches Playlist/Artist/Album/Genre/Composer.

⑪ **Mute Button**

Press this button to lower the volume by 20 dB instantly. Press this button again to cancel.

Operating the Audio Processor

1 Press A.PROC to select the mode.

Normal mode → Time Correction → X-OVER → Normal mode

2 Press ▲ or ▼ to select the item.

Time Correction mode/Crossover (X-OVER) mode:

Select from MEMORY 1 through 6.

Battery Replacement

Applicable battery: Use two "AAA" sized dry batteries or equivalent.

1 Opening the battery cover

Slide out the battery cover while firmly pressing in the direction of the arrow.

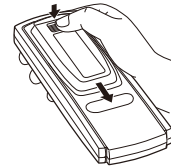

2 Replacing the battery

Insert the batteries, observing the polarities as illustrated.

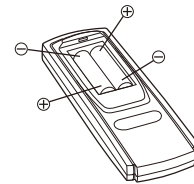

3 Closing the cover

Slide the cover as illustrated until a click is heard.

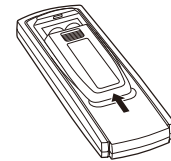

Controllable With Remote Control

Point the remote control transmitter at the remote control sensor.

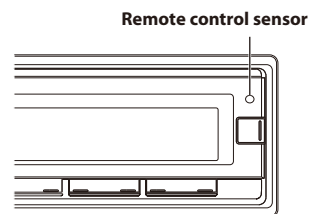

Connectable to Remote Control Interface Box

This unit may be controlled from the vehicle's audio controls. An optional Alpine Remote Control Interface Box must be used. For details, contact your Alpine dealer.

Information

In Case of Difficulty

If you encounter a problem, please turn the power off, then on again. If the unit is still not functioning normally, please review the items in the following checklist. This guide will help you isolate the problem if the unit is at fault. Otherwise, make sure the rest of your system is properly connected or consult your authorized Alpine dealer.

Basic

No function or display.

- Vehicle's ignition is off.
 - If connected following instructions, the unit will not operate with the vehicle's ignition off.
- Improper power lead (Red) and battery lead (Yellow) connections.
 - Check power lead and battery lead connections.
- Blown fuse.
 - Check the fuse of the unit; replace with the proper value if necessary.
- Internal micro-computer malfunctioned due to interference noise etc.
 - Press the **RESET** button with a ballpoint pen or other pointed article.

Radio

Unable to receive stations.

- No antenna or open connection in cable.
 - Make sure the antenna is properly connected; replace the antenna or cable if necessary.

Unable to tune stations in the seek mode.

- You are in a weak signal area.
 - Make sure the tuner is in the DX mode.
- If the area you are in is a primary signal area, the antenna may not be grounded and connected properly.
 - Check your antenna connections; make sure the antenna is properly grounded at its mounting location.
- The antenna may not be the proper length.
 - Make sure the antenna is fully extended; if broken, replace the antenna with a new one.

Broadcast is noisy.

- The antenna is not the proper length.
 - Extend the antenna fully; replace it if it is broken.
- The antenna is poorly grounded.
 - Make sure the antenna is grounded properly at its mounting location.

CD

CD Player not functioning.

- Out of operating temperature range +50°C (+120°F) for CD.
 - Allow the vehicle's interior (or trunk) temperature to cool.

CD playback sound is wavering.

- Moisture condensation in the CD Module.
 - Allow enough time for the condensation to evaporate (about 1 hour).

CD insertion not possible.

- A CD is already in the CD player.
 - Eject the CD and remove it.

- The CD is being improperly inserted.
 - Make sure the CD is being inserted following instructions in the CD Player Operation section.

Unable to fast forward or backward the CD.

- The CD has been damaged.
 - Eject the CD and discard it; using a damaged CD in your unit can cause damage to the mechanism.

CD playback sound skips due to vibration.

- Improper mounting of the unit.
 - Securely re-mount the unit.
- The disc is very dirty.
 - Clean the disc.
- The disc has scratches.
 - Change the disc.
- The pick-up lens is dirty.
 - Do not use a commercially available lens cleaner disc. Consult your nearest Alpine dealer.

CD playback sound skips without vibration.

- The disc is dirty or scratched.
 - Clean the disc; damaged disc should be replaced.

Error displays (built-in CD player only).

- Mechanical error.
 - Press **▲**. After the error indication disappears, insert the disc again. If the above-mentioned solution does not solve the problem, consult your nearest Alpine dealer.

CD-R/CD-RW playback not possible.

- Close session (finalization) has not been performed.
 - Perform finalization and attempt playback again.

MP3/WMA/AAC

MP3/WMA is not played back.

- Writing error occurred. The MP3/WMA/AAC format is not compatible.
 - Make sure the MP3/WMA/AAC has been written in a supported format. Refer to "About MP3/WMA/AAC" on page 11, and then rewrite in the format supported by this device.

Audio

The sound is not output from the speakers.

- Unit has no output signal of the internal amplifier.
 - POWER IC is switched to "ON", refer to "Connecting to an External Amplifier" on page 19.

iPod

iPod does not play and no sound is output.

- The iPod has not been recognized.
 - Reset this unit and the iPod. Refer to "Initial System Start-Up" on page 7. To reset the iPod, refer to the Owner's Manual of the iPod.

Indication for CD Player

No Disc

- No CD is inserted.
 - Insert a CD.
- Although a disc is inserted, "No Disc" is displayed and the unit does not start to play or eject the disc.
 - Remove the disc by following these steps:
 - Press the **▲** button again for at least 2 seconds.
 - If the disc still does not eject, consult your Alpine dealer.

Error

- Mechanism error.
 - 1 Press the **▲** button and eject the CD.
 - If not ejecting, consult your Alpine dealer.
 - 2 When the error indication remains after ejecting, press the **▲** button again.
 - If the error indication still does not turn off after pressing the **▲** button for a few times, consult your Alpine dealer.
- When "ERROR" is displayed:
 - If the disc cannot be ejected by pressing **▲**, press the **RESET** button (refer to "Initial System Start-Up" on page 7) and press **▲** again. If the disc still cannot be ejected, consult your Alpine dealer.

PROTECT

- A copy-protected WMA file was played back.
 - You can only play back non-copy-protected files.

UNSUPPORTED

- A sampling rate/bit rate not supported by the unit is used.
 - Use a sampling rate/bit rate that is supported by the unit.

Indication for CD Changer

High Temperature

- Protective circuit is activated due to high temperature.
 - The indication will disappear when the temperature returns to normal operating range

Error 01

- Malfunction in the CD Changer.
 - Consult your Alpine dealer. Press the magazine eject button and pull out the magazine. Check the indication. Insert the magazine again. If the magazine cannot be pulled out, consult your Alpine dealer.
- Magazine ejection not possible.
 - Press the magazine eject button. If the magazine does not eject, consult your Alpine dealer.

Error 02

- A disc is left inside the CD Changer.
 - Press the eject button to activate the eject function. When the CD Changer finishes the eject function, insert an empty CD magazine into the CD Changer to receive the disc left inside the CD Changer.

No Magazine

- No magazine is loaded into the CD Changer.
 - Insert a magazine.

No Disc

- No indicated disc.
 - Choose another disc.
-

Indication for USB Memory

Error 01

- Database error or decoder error
 - You can solve the problem by switching the source.
-

Error 02

- Communication error or boot error, etc.
 - You can solve the problem by reconnecting the USB Memory or changing source.
-

Current Error

- Abnormal current is run to the USB connector device.
 - You can solve the problem by switching the source.
-

Device Error

- A USB device that is not supported by the unit is connected.
 - Connect a USB device that is supported by the unit.
-

No USB Unit

- A USB Memory is not connected.
 - Make sure the USB Memory device is correctly connected and the cable is not excessively bent.
-

NO FILE

- No song (file) is stored in the USB Memory
 - Connect the USB Memory device after storing songs (files).
-

UNSUPPORTED

- A sampling rate/bit rate not supported by the unit is used.
 - Use a sampling rate/bit rate that is supported by the unit.
-

PROTECT

- A copy-protected WMA file was played back.
 - You can only play back non-copy-protected files.
-

Indication for iPod Mode

No USB Unit

- The iPod/iPhone is not connected.
 - Make sure the iPod/iPhone is correctly connected (refer to "Connections" on page 50). Make sure the cable is not bent excessively.
-

NO SONG

- There are no songs in the iPod/iPhone.
 - Download songs to the iPod/iPhone and connect to this unit.
-

Error 01

- Database error or decoder error.
 - You can solve the problem by switching the source.
-

Error 02

- Communication error or boot error, etc.
 - You can solve the problem by reconnecting the iPod/iPhone or changing source.
-

Error 03

- The iPod/iPhone is not verified.
 - You can solve the problem by reconnecting the iPod/iPhone.
-

Current Error

- Abnormal current is run to the USB connector device.
 - You can solve the problem by switching the source.
-

Device Error

- A USB device that is not supported by the unit is connected.
 - Connect a USB device that is supported by the unit.
-

BLUETOOTH mode

No Unit

- The BLUETOOTH device is not connected.
 - Connect the BLUETOOTH device.
-

Specifications

Note

- Due to continuous product improvement, specifications and design are subject to change without notice.

FM TUNER SECTION

Tuning Range	87.5~108.0 MHz
Mono Usable Sensitivity	9.3 dBf (0.8 μ V/75 ohms)
Alternate Channel Selectivity	80 dB
Signal-to-Noise Ratio	65 dB
Stereo Separation	35 dB
Capture Ratio	2.0 dB

AM TUNER SECTION

Tuning Range	531~1,602 kHz
--------------	---------------

CD PLAYER SECTION

Frequency Response	5~20,000 Hz (\pm 1 dB)
Wow & Flutter (% WRMS)	Below measurable limits
Total Harmonic Distortion	0.008% (at 1 kHz)
Dynamic Range	95 dB (at 1 kHz)
Signal-to-Noise Ratio	105 dB
Channel Separation	85 dB (at 1 kHz)

PICKUP

Wave length	795 nm
Laser power	CLASS I

USB SECTION

USB requirements	USB 1.1/2.0
Max. Power Consumption	500 mA
USB Class	Mass Storage
File System	FAT 12/16/32
MP3 Decoding	MPEG AUDIO Layer-3
WMA Decoding	Windows Media™ Audio
AAC Decoding	AAC-LC format ".m4a" file
Number of Channels	2-Channel (Stereo)
Frequency Response*	5-20,000 Hz (\pm 1 dB)
Total Harmonic Distortion	0.008% (at 1 kHz)
Dynamic Range	95 dB (at 1 kHz)
Signal-to-Noise Ratio	105 dB
Channel Separation	85 dB (at 1 kHz)

* Frequency response may differ depending on the encoder software/bit rate.

BLUETOOTH SECTION

BLUETOOTH Specification	BLUETOOTH V 3.0
Output Power	+4 dBm Max. (Power class 2)
Profile	HFP (Hands-Free Profile) HSP (Head Set Profile) A2DP (Advanced Audio Distribution Profile) AVRCP (Audio/Video Remote Control Profile)

GENERAL

Power Requirement	14.4 V DC (11~16 V allowable)
Maximum Power Output	50 W \times 4
Maximum Pre-Output Voltage	4 V/10 k ohms
Weight	1.53 kg (3 lbs. 5 oz)

CHASSIS SIZE

Width	178 mm (6~15/16")
Height	50 mm (2")
Depth	162 mm (6-3/8")

NOSEPIECE SIZE

Width	170 mm (6-3/4")
Height	46 mm (1-13/16")
Depth	24 mm (15/16")

Installation and Connections

Before installing or connecting the unit, please read the following and refer to “Operating Instructions” on page 3 for proper use.

WARNING

MAKE THE CORRECT CONNECTIONS.

Failure to make the proper connections may result in fire or product damage.

USE ONLY IN CARS WITH A 12 VOLT NEGATIVE GROUND.

(Check with your dealer if you are not sure.) Failure to do so may result in fire, etc.

BEFORE WIRING, DISCONNECT THE CABLE FROM THE NEGATIVE BATTERY TERMINAL.

Failure to do so may result in electric shock or injury due to electrical shorts.

DO NOT ALLOW CABLES TO BECOME ENTANGLED IN SURROUNDING OBJECTS.

Arrange wiring and cables in compliance with the manual to prevent obstructions when driving. Cables or wiring that obstruct or hang up on places such as the steering wheel, shift lever, brake pedals, etc. can be extremely hazardous.

DO NOT SPLICE INTO ELECTRICAL CABLES.

Never cut away cable insulation to supply power to other equipment. Doing so will exceed the current carrying capacity of the wire and result in fire or electric shock.

DO NOT DAMAGE PIPE OR WIRING WHEN DRILLING HOLES.

When drilling holes in the chassis for installation, take precautions so as not to contact, damage or obstruct pipes, fuel lines, tanks or electrical wiring. Failure to take such precautions may result in fire.

DO NOT USE BOLTS OR NUTS IN THE BRAKE OR STEERING SYSTEMS TO MAKE GROUND CONNECTIONS.

Bolts or nuts used for the brake or steering systems (or any other safety-related system), or tanks should NEVER be used for installations or ground connections. Using such parts could disable control of the vehicle and cause fire etc.

KEEP SMALL OBJECTS SUCH AS BATTERIES OUT OF THE REACH OF CHILDREN.

Swallowing them may result in serious injury. If swallowed, consult a physician immediately.

DO NOT INSTALL IN LOCATIONS WHICH MIGHT HINDER VEHICLE OPERATION, SUCH AS THE STEERING WHEEL OR SHIFT LEVER.

Doing so may obstruct forward vision or hamper movement etc. and results in serious accident.

CAUTION

HAVE THE WIRING AND INSTALLATION DONE BY EXPERTS.

The wiring and installation of this unit requires special technical skill and experience. To ensure safety, always contact the dealer where you purchased this product to have the work done.

USE SPECIFIED ACCESSORY PARTS AND INSTALL THEM SECURELY.

Be sure to use only the specified accessory parts. Use of other than designated parts may damage this unit internally or may not securely install the unit in place. This may cause parts to become loose resulting in hazards or product failure.

ARRANGE THE WIRING SO IT IS NOT CRIMPED OR PINCHED BY A SHARP METAL EDGE.

Route the cables and wiring away from moving parts (like the seat rails) or sharp or pointed edges. This will prevent crimping and damage to the wiring. If wiring passes through a hole in metal, use a rubber grommet to prevent the wire's insulation from being cut by the metal edge of the hole.

DO NOT INSTALL IN LOCATIONS WITH HIGH MOISTURE OR DUST.

Avoid installing the unit in locations with high incidence of moisture or dust. Moisture or dust that penetrates into this unit may result in product failure.

PRECAUTIONS

- Be sure to disconnect the cable from the (-) battery post before installing your CDA-137EBT. This will reduce any chance of damage to the unit in case of a short-circuit.
- Be sure to connect the colour coded leads according to the diagram. Incorrect connections may cause the unit to malfunction or damage to the vehicle's electrical system
- When making connections to the vehicle's electrical system, be aware of the factory installed components (e.g. on-board computer). Do not tap into these leads to provide power for this unit. When connecting the CDA-137EBT to the fuse box, make sure the fuse for the intended circuit of the CDA-137EBT has the appropriate amperage. Failure to do so may result in damage to the unit and/or the vehicle. When in doubt, consult your Alpine dealer.
- The CDA-137EBT uses female RCA-type jacks for connection to other units (e.g. amplifier) having RCA connectors. You may need an adaptor to connect other units. If so, please contact your authorized Alpine dealer for assistance.
- Be sure to connect the speaker (-) leads to the speaker (-) terminal. Never connect left and right channel speaker cables to each other or to the vehicle body.

IMPORTANT

Please record the serial number of your unit in the space provided below and keep it as a permanent record. The serial number or the engraved serial number is located on the bottom of the unit.

SERIAL NUMBER: []
INSTALLATION DATE: []
INSTALLATION TECHNICIAN: []
PLACE OF PURCHASE: []

Installation

CAUTION

When you install this unit in your car, do not remove the detachable front panel. If the detachable front panel is removed during installation, you might press too hard and warp the metal plate that holds it in place. The main unit must be mounted within 35 degrees of the horizontal plane, back to front.

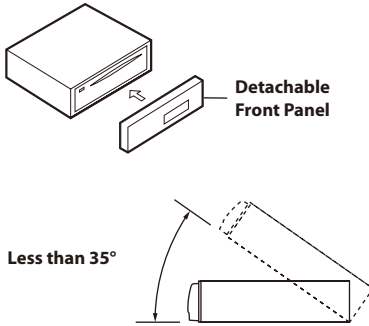

- 1 Remove the mounting sleeve from the main unit (refer to "Removal" on page 48).

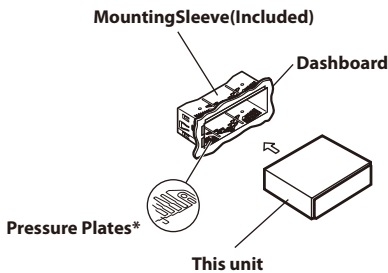

* If the installed mounting sleeve is loose in the dashboard, the pressure plates may be bent slightly to remedy the problem.

- 2 Reinforce the head unit with the metal mounting strap (not supplied). Secure the ground lead of the unit to a clean metal spot using a screw (*1) already attached to the vehicle's chassis.

Connect each input lead coming from an amplifier or equalizer to the corresponding output lead coming from the left rear of the CDA-137EBT. Connect all other leads of the CDA-137EBT according to details described in the CONNECTIONS section.

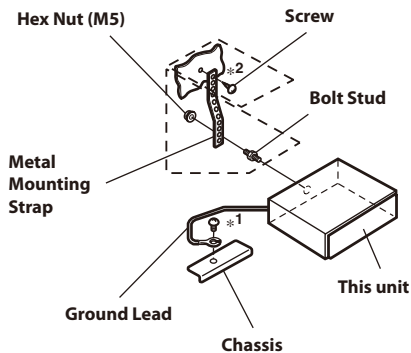

Note

- For the screw marked "*2", use an appropriate screw for the chosen mounting location.

- 3 Slide the CDA-137EBT into the dashboard until it clicks. This ensures that the unit is properly locked and will not accidentally come out from the dashboard.

Removal

- 1 Remove the detachable front panel.
- 2 Insert the bracket keys into the unit, along the guides on either side. The unit can now be removed from the mounting sleeve.

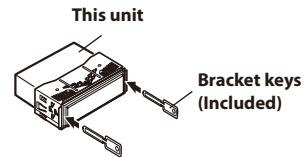

- 3 Pull the unit out, keeping it unlocked as you do so.

JAPANESE CAR

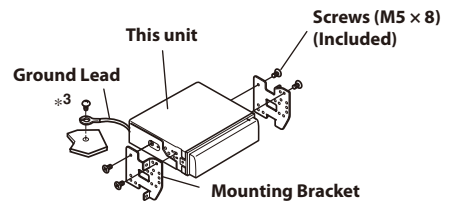
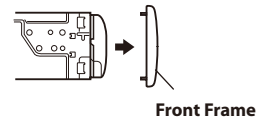

Note

- Secure the ground lead of the unit to a clean metal spot using a screw (*3) already attached to the vehicle's chassis.

iPod/iPhone Connection (sold separately)

Connect USB cable to an iPod/iPhone with Interface cable for iPod.

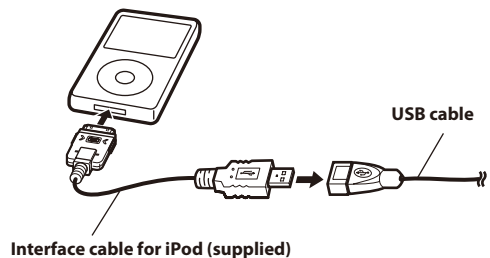

Remove the iPod/iPhone

Remove the iPod/iPhone from Interface cable for iPod.



Note

- After changing the unit to a source other than the USB iPod, remove the iPod/iPhone. If the iPod/iPhone is removed in the USB iPod mode, data may cause damage.
- If sound is not output or the iPod/iPhone is not recognized even when the iPod/iPhone is connected, remove the iPod/iPhone once, then connect it again, or reset the iPod.
- Do not leave the iPod/iPhone in a vehicle for a long time. Heat and humidity may damage the iPod/iPhone and you may not be able to play it again.

USB Memory Connection (sold separately)

Connect USB Memory

Connect the USB cable to the USB connector of the unit, and then secure the connection using the lock case supplied with USB cable as shown below.

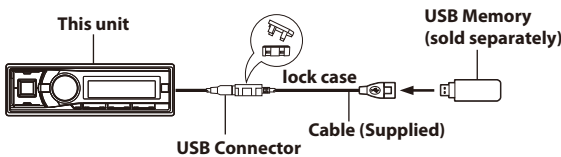

Remove USB Memory

Pull out USB Memory squarely from the USB cable.

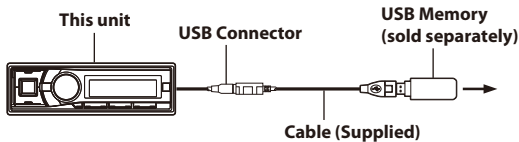

Note

- When removing USB Memory, pull it out straight..
- If sound is not output or USB Memory is not recognized even when USB Memory is connected, remove USB Memory once, then connect it again.
- Change to a source other than the USB Memory mode, then remove the USB Memory. If the USB Memory is removed in the USB Memory mode, data may be damaged.
- Route the USB cable away from another cables.

Mounting the Microphone

For the sake of safety, mount the microphone in the following location.

- In a stable and secure location.
- In a location that does not inhibit safely driving the vehicle.
- Mount the microphone in a location where the driver's voice can easily be picked up.

Choose a location for the microphone that can easily pick up the driver's voice. Requiring the driver to move towards the microphone for audibility causes a distraction that could be dangerous.

Connections

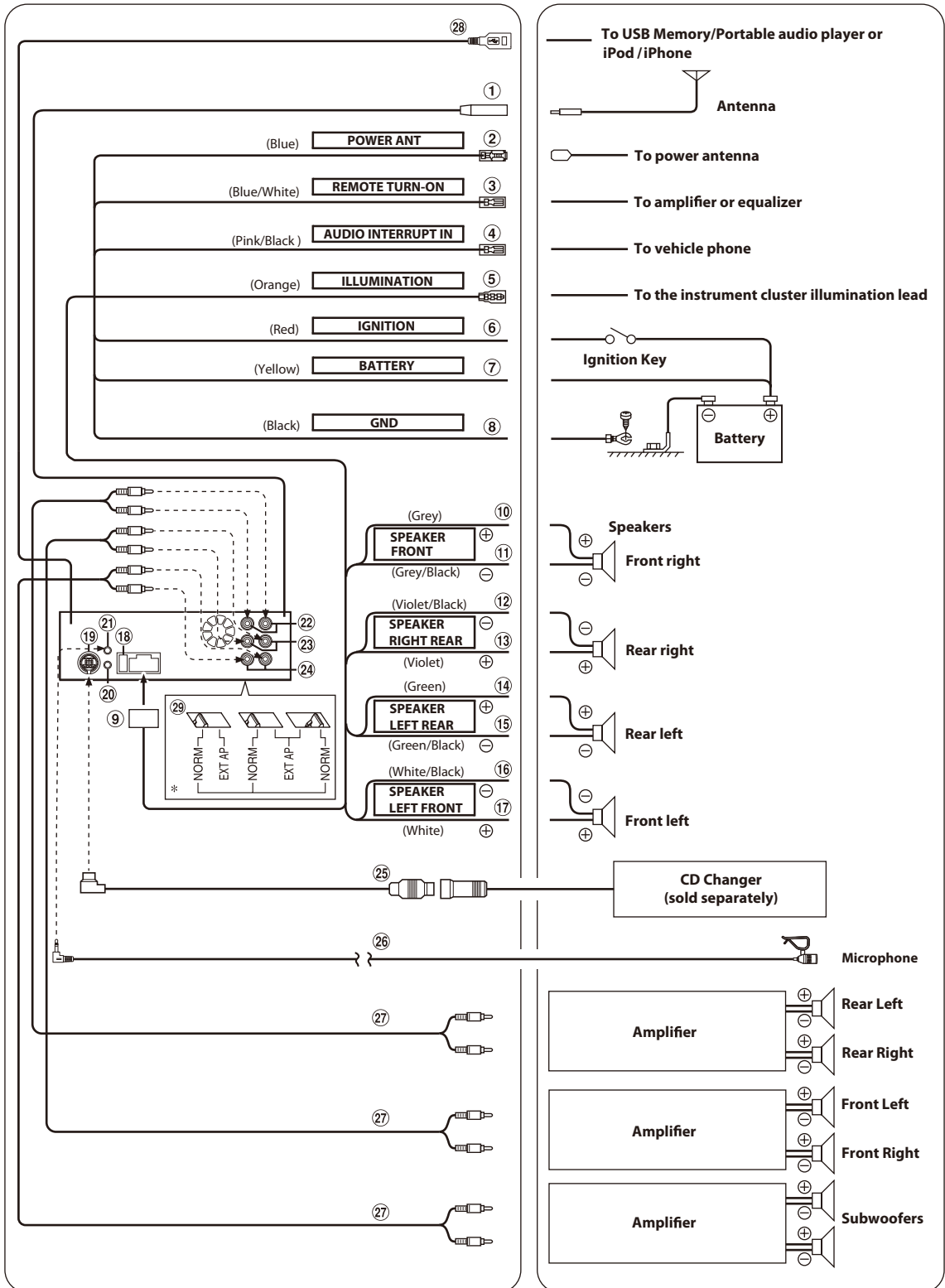

* The system switch is located on the bottom of the unit.

- ① **Antenna Receptacle.**
- ② **Power Antenna Lead (Blue)**
Connect this lead to the +B terminal of your power antenna, if applicable.
Note
 - *This lead should be used only for controlling the vehicle's power antenna. Do not use this lead to turn on an amplifier or a signal processor, etc.*
- ③ **Remote Turn-On Lead (Blue/White)**
Connect this lead to the remote turn-on lead of your amplifier or signal processor.
- ④ **Audio Interrupt In Lead (Pink/Black)**
Connect this lead to the Audio Interface output of a cellular phone which provides ground shorting when a call is received.
- ⑤ **Illumination Lead (Orange)**
This lead may be connected to the vehicle's instrument cluster illumination lead. This will allow the backlighting of this unit to dim whenever the vehicle's lights are turned on.
- ⑥ **Switched Power Lead (Ignition) (Red)**
Connect this lead to an open terminal on the vehicle's fuse box or another unused power source which provides (+) 12V only when the ignition is turned on or in the accessory position.
- ⑦ **Battery Lead (Yellow)**
Connect this lead to the positive (+) post of the vehicle's battery.
- ⑧ **Ground Lead (Black)**
Connect this lead to a good chassis ground on the vehicle. Make sure the connection is made to bare metal and is securely fastened using the sheet metal screw provided.
- ⑨ **Power Supply Connector**
- ⑩ **Right Front (+) Speaker Output Lead (Grey)**
- ⑪ **Right Front (-) Speaker Output Lead (Grey/Black)**
- ⑫ **Right Rear (-) Speaker Output Lead (Violet/Black)**
- ⑬ **Right Rear (+) Speaker Output Lead (Violet)**
- ⑭ **Left Rear (+) Speaker Output Lead (Green)**
- ⑮ **Left Rear (-) Speaker Output Lead (Green/Black)**
- ⑯ **Left Front (-) Speaker Output Lead (White/Black)**
- ⑰ **Left Front (+) Speaker Output Lead (White)**
- ⑱ **Fuse Holder (10A)**
- ⑲ **Ai-NET Connector**
Connect this to the output or input connector of other product (CD changer, IMPRINT audio processor, Equalizer, etc.) equipped with Ai-NET.
Note
 - *Interface adapter for iPod (KCA-420i) is not recommended for use with this product.*
 - *You can input TV/video sound by connecting an optional Ai-NET/ RCA Interface cable (KCA-121B) to this component.*
 - *Be sure to set "Setting the Connected Head Unit (MODEL SETUP)" to "CD CHG", when the DHA-S690 is connected.*
- ⑳ **Steering Remote Control Interface Connector**
To steering remote control interface box. For details, contact your Alpine dealer.
- ㉑ **MIC Input Connector**
To Microphone.

- ㉒ **Rear Output Input RCA Connectors**
It can be used as Rear Output or Input RCA connectors. RED is right and WHITE is left.
- ㉓ **Front Output Input RCA Connectors**
It can be used as Front Output or Input RCA connectors. RED is right and WHITE is left.
- ㉔ **Subwoofer Output RCA Connectors**
RED is right and WHITE is left.
- ㉕ **Ai-NET Cable (Included with CD Changer)**
- ㉖ **Microphone (Included).**
- ㉗ **RCA Extension Cable (sold separately)**
- ㉘ **USB Connector**
Connect this to an USB Memory/Portable audio player or to an iPod/iPhone. To use an iPod/iPhone, Interface cable for iPod connection is required.
Note
 - *Use the supplied USB cable. If a USB cable other than the supplied is used, correct performance cannot be guaranteed.*
 - *Route the USB cable away from other cables.*

To prevent external noise from entering the audio system.

- **Locate the unit and route the leads at least 10 cm away from the car harness.**
- **Keep the battery power leads as far away from other leads as possible.**
- **Connect the ground lead securely to a bare metal spot (remove any paint, dirt or grease if necessary) of the car chassis.**
- **If you add an optional noise suppressor, connect it as far away from the unit as possible. Your Alpine dealer carries various noise suppressors, contact them for further information.**
- **Your Alpine dealer knows best about noise prevention measures so consult your dealer for further information.**

To prevent external noise from entering the audio system.

- **Locate the unit and route the leads at least 10 cm away from the car harness.**
- **Keep the battery power leads as far away from other leads as possible.**
- **Connect the ground lead securely to a bare metal spot (remove any paint, dirt or grease if necessary) of the car chassis.**
- **If you add an optional noise suppressor, connect it as far away from the unit as possible. Your Alpine dealer carries various noise suppressors, contact them for further information.**
- **Your Alpine dealer knows best about noise prevention measures so consult your dealer for further information.**

TRA
REGISTERED No:
ER0072756/11
DEALER No:
DA0042125/10

About the Rules of Bluetooth Electromagnetic Radiation Regulation

Thailand	This telecommunication equipment conforms to NTC technical requirement.
-----------------	---