



EN

FR

ES

# MRV-V500

## 4 CHANNEL + MONO POWER AMPLIFIER

- OWNER'S MANUAL  
Please read before using this equipment.
- MODE D'EMPLOI  
Veuillez lire avant d'utiliser cet appareil.
- MANUAL DE OPERACIÓN  
Léalo antes de utilizar este equipo.

---

#### ALPINE ELECTRONICS MARKETING, INC.

1-7, Yukigaya-Otsukamachi, Ota-ku,  
Tokyo 145-0067, JAPAN  
Phone: 03-5499-4531

#### ALPINE ELECTRONICS OF AMERICA, INC.

19145 Gramercy Place, Torrance,  
California 90501, U.S.A.  
Phone 1-800-ALPINE-1 (1-800-257-4631)

#### ALPINE ELECTRONICS OF AUSTRALIA PTY. LTD.

161-165 Princes Highway, Hallam  
Victoria 3803, Australia  
Phone 03-8787-1200

#### ALPINE ELECTRONICS GmbH

Wilhelm-Wagenfeld-Str. 1-3,  
80807 München, Germany  
Phone 089-32 42 640

#### ALPINE ELECTRONICS OF U.K. LTD.

Alpine House  
Fletchamstead Highway, Coventry CV4 9TW, U.K.  
www.alpine.co.uk

#### ALPINE ELECTRONICS FRANCE S.A.R.L.

(RCS PONTOISE B 338 101 280)  
98, Rue de la Belle Etoile, Z.I. Paris Nord II,  
B.P. 50016, 95945 Roissy Charles de Gaulle  
Cedex, France  
Phone +33-(0)1-48638989

#### ALPINE ITALIA S.p.A.

Viale Cristoforo Colombo, 8  
20090 Trezzano sul Naviglio MI, Italy  
Phone +39 02 484781

#### ALPINE ELECTRONICS DE ESPAÑA, S.A.

Portal de Gamarra 36, Pabellón, 32  
01013 Vitoria (Alava)-APDO 133, Spain  
Phone 945-283588



## CONTENTS

WARNING.....	1
SERVICE CARE .....	2
ACCESSORIES .....	2
INSTALLATION.....	3
ATTACHING THE TERMINAL COVERS.....	3
CONNECTIONS .....	4
CONNECTION CHECK LIST.....	8
SWITCH SETTINGS.....	9
SYSTEM DIAGRAMS .....	11
SPECIFICATIONS.....	14

## WARNING

### Points to Observe for Safe Usage

Read this manual carefully before using the system components. They contain instructions on how to use this product in a safe and effective manner. Alpine cannot be responsible for problems resulting from failure to observe the instructions in this manual.

#### WARNING

This symbol means important instructions. Failure to heed them can result in serious injury or death.

#### **DO NOT OPERATE ANY FUNCTION THAT TAKES YOUR ATTENTION AWAY FROM SAFELY DRIVING YOUR VEHICLE.**

Any function that requires your prolonged attention should only be performed after coming to a complete stop. Always stop the vehicle in a safe location before performing these functions. Failure to do so may result in an accident.

#### **KEEP THE VOLUME AT A LEVEL WHERE YOU CAN STILL HEAR OUTSIDE NOISES WHILE DRIVING.**

Excessive volume levels that obscure sounds such as emergency vehicle sirens or road warning signals (train crossings, etc.) can be dangerous and may result in an accident. LISTENING AT LOUD VOLUME LEVELS IN A CAR MAY ALSO CAUSE HEARING DAMAGE.

#### **DO NOT DISASSEMBLE OR ALTER.**

Doing so may result in an accident, fire or electric shock.

#### **USE THIS PRODUCT FOR MOBILE 12V APPLICATIONS.**

Use for other than its designed application may result in fire, electric shock or other injury.

#### **USE THE CORRECT AMPERE RATING WHEN REPLACING FUSES.**

Failure to do so may result in fire or electric shock.

#### **DO NOT BLOCK VENTS OR RADIATOR PANELS.**

Doing so may cause heat to build up inside and may result in fire.

#### **MAKE THE CORRECT CONNECTIONS.**

Failure to make the proper connections may result in fire or product damage.

#### **USE ONLY IN CARS WITH A 12 VOLT NEGATIVE GROUND.**

(Check with your dealer if you are not sure.) Failure to do so may result in fire, etc.

#### **BEFORE WIRING, DISCONNECT THE CABLE FROM THE NEGATIVE BATTERY TERMINAL.**

Failure to do so may result in electric shock or injury due to electrical shorts.

#### **DO NOT ALLOW CABLES TO BECOME ENTANGLED IN SURROUNDING OBJECTS.**

Arrange wiring and cables in compliance with the manual to prevent obstructions when driving. Cables or wiring that obstruct or hang up on places such as the steering wheel, gear lever, brake pedals, etc. can be extremely hazardous.

#### **DO NOT SPLICE INTO ELECTRICAL CABLES.**

Never cut away cable insulation to supply power to other equipment. Doing so will exceed the current carrying capacity of the wire and result in fire or electric shock.

#### **DO NOT DAMAGE PIPE OR WIRING WHEN DRILLING HOLES.**

When drilling holes in the chassis for installation, take precautions so as not to contact, damage or obstruct pipes, fuel lines, tanks or electrical wiring. Failure to take such precautions may result in fire.

**DO NOT USE BOLTS OR NUTS IN THE BRAKE OR STEERING SYSTEMS TO MAKE GROUND CONNECTIONS.**

Bolts or nuts used for the brake or steering systems (or any other safety-related system), or tanks should NEVER be used for installations or ground connections. Using such parts could disable control of the vehicle and cause fire etc.

**KEEP SMALL OBJECTS SUCH AS BATTERIES OUT OF THE REACH OF CHILDREN.**

Swallowing them may result in serious injury. If swallowed, consult a physician immediately.

 <b>CAUTION</b>	This symbol means important instructions. Failure to heed them can result in injury or property damages.
---	--

**HALT USE IMMEDIATELY IF A PROBLEM APPEARS.**

Failure to do so may cause personal injury or damage to the product. Return it to your authorized Alpine dealer or the nearest Alpine Service Center for repairing.

**HAVE THE WIRING AND INSTALLATION DONE BY EXPERTS.**

The wiring and installation of this unit requires special technical skill and experience. To ensure safety, always contact the dealer where you purchased this product to have the work done.

**USE SPECIFIED ACCESSORY PARTS AND INSTALL THEM SECURELY.**

Be sure to use only the specified accessory parts. Use of other than designated parts may damage this unit internally or may not securely install the unit in place. This may cause parts to become loose resulting in hazards or product failure.

**ARRANGE THE WIRING SO IT IS NOT CRIMPED OR PINCHED BY A SHARP METAL EDGE.**

Route the cables and wiring away from moving parts (like the seat rails) or sharp or pointed edges. This will prevent crimping and damage to the wiring. If wiring passes through a hole in metal, use a rubber grommet to prevent the wire's insulation from being cut by the metal edge of the hole.

**DO NOT INSTALL IN LOCATIONS WITH HIGH MOISTURE OR DUST.**

Avoid installing the unit in locations with high incidence of moisture or dust. Moisture or dust that penetrates into this unit may result in product failure.

## SERVICE CARE

**◆ IMPORTANT NOTICE**

This Amplifier has been type tested and found to comply with the limits for a Class B computing device in accordance with the specifications in Subpart J of Part 15 of FCC Rules. This equipment generates and uses radio frequency energy, and it must be installed and used properly in accordance with the manufacturer's instructions.

SERIAL NUMBER:	_____
INSTALLATION DATE:	_____
INSTALLATION TECHNICIAN:	_____
PLACE OF PURCHASE:	_____

**◆ IMPORTANT**

Please record the serial number of your unit in the space provided here and keep it as a permanent record. The serial number plate is located on the rear of the unit.

**◆ For European Customers**

Should you have any questions about warranty, please consult your store of purchase.

**◆ For Customers in other Countries**

**IMPORTANT NOTICE**

Customers who purchase the product with which this notice is packaged, and who make this purchase in countries other than the United States of America and Canada, please contact your dealer for information regarding warranty coverage.

## ACCESSORIES

- Self-Tapping Screw (M4 × 20).....4
- Terminal Cover ..... 1 SET
- Speaker Input Connector..... 1
- Hexagon Wrench (Large/Small).....1 SET

## INSTALLATION

Due to the high power output of the MRV-V500 considerable heat is produced when the amplifier is in operation. For this reason, the amplifier should be mounted in a location which will allow for free circulation of air, such as inside the trunk. For alternate installation locations, please contact your authorized Alpine dealer.

1. Using the amplifier as a template, mark the four screw locations.
2. Make sure there are no objects behind the surface that may become damaged during drilling.
3. Drill the screw holes.
4. Position the MRV-V500 over the screw holes, and secure with four self-tapping screws. (Fig. 1)

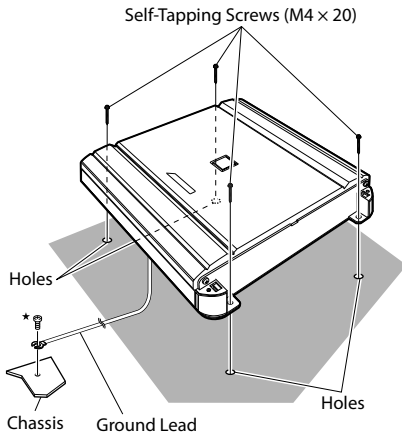

Fig. 1

### NOTE:

- To securely connect the ground lead, use an already installed screw on a metal part of the vehicle (marked (★)) or a clean, bare metal spot on the vehicle's chassis. Be sure this is a good ground by checking continuity to the battery (-) terminal. Connect all equipment to the same ground point while keeping wire length as short as possible. These procedures will help eliminate noise.

## ATTACHING THE TERMINAL COVERS

Attach the terminal covers (included) after connections and confirmation of correct operation. Attaching the terminal covers will improve the appearance of the unit.

### How to attach the terminal covers:

Attach the terminal covers to the main unit. (Fig.2)

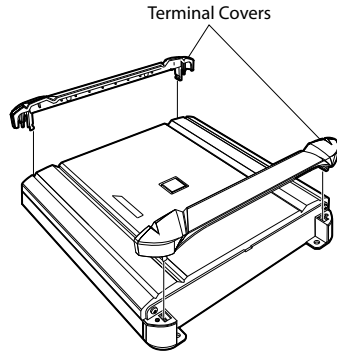

Fig. 2



### CAUTION

Do not lift or carry the unit by the attached terminal covers.

# CONNECTIONS

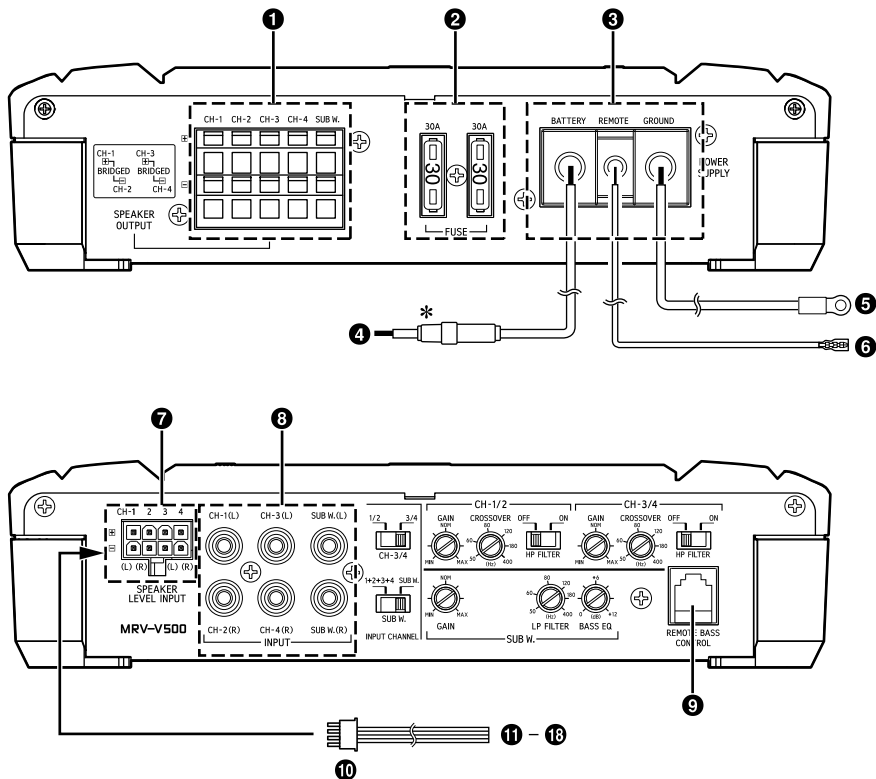

**Fig. 3**

\* Be sure to add an in-line fuse with the battery lead as close as possible to the battery's positive (+) terminal.

Before making connections, be sure to turn the power off to all audio components. Connect the battery lead from the amp directly to the positive (+) terminal of the vehicle's battery with appropriate in-line vehicle's fuse (see Battery Lead section). Do not connect this lead to the vehicle's fuse block.

### To prevent external noise from entering the audio system

- Locate the unit and route the leads at least 10 cm (4") away from the vehicle's harness.
- Keep the battery power leads as far away from other leads as possible.
- Connect the ground lead securely to a bare metal spot (remove any paint or grease if necessary) of the vehicle's chassis.

- If you add an optional noise suppressor, connect it as far away from the unit as possible. Your Alpine dealer carries various noise suppressors, contact them for further information.
- Your Alpine dealer knows best about noise prevention measures so consult your dealer for further information.

### 1 Speaker Output Terminals

- The speaker terminals of this unit are insert terminal type.

Be sure to observe correct speaker output connections and polarity in relation to the other speakers in the system. Connect the positive output to the positive speaker terminal and the negative to negative.

#### About Subwoofer Input/Output Terminals

- The input is stereo but the output is monaural.
- Reversing subwoofer polarity (swapping positive and negative connections to the subwoofer) may be desirable in some installations for optimum bass performance.

#### About Bridged Connections

In the bridged mode, connect the left positive to the positive terminal of the speaker and the right negative to the negative terminal of the speaker. Do not use the speaker (-) terminals as a common lead between the left and right channels.

#### NOTE:

- Do not connect the speaker (-) terminal to the vehicle's chassis.

### 2 Fuse

MRV-V500.....30 A x 2

#### USE THE CORRECT AMPERE RATING WHEN REPLACING FUSES.

Failure to do so may result in fire or electric shock.

### 3 Power Supply Terminal

#### 4 Battery Lead (Sold Separately)

Be sure to add an in-line fuse with the battery lead as close as possible to the battery's positive (+) terminal. This fuse will protect your vehicle's electrical system in case of a short circuit. See below for appropriate fuse value and minimum wire gauge requirement:

MRV-V500..... 60 amp fuse, 4 AWG/21 mm<sup>2</sup>

#### 5 Ground Lead (Sold Separately)

Connect this lead securely to a clean, bare metal spot on the vehicle's chassis. Verify this point to be a true ground by checking for continuity between that point and the negative (-) terminal of the vehicle's battery. Ground all your audio components to the same point on the chassis to prevent ground loops while keeping wire length as short as possible.

Minimum required wire gauge for this connection is as follows:

MRV-V500.....4 AWG/21 mm<sup>2</sup>

#### 6 Remote Turn-On Lead (Sold Separately)

Connect this lead to the remote turn-on (positive trigger, (+) 12 V only) lead of your head unit. If a remote turn-on lead is not available, see "CONNECTION CHECK LIST" section on page 8 for alternative method.

#### NOTE:

- When connecting the speaker output leads of the head unit to this unit with a Speaker Input Connector (included), you do not need to connect the remote turn-on lead, owing to the "REMOTE SENSING" function of this unit. However, the "REMOTE SENSING" function may not work depending on the signal source connected. In such a case, connect the remote turn-on lead to an incoming power supply cord (accessory power) in the ACC position.

#### 7 Speaker Level Input Connector

These input leads are for use with head units not equipped with preamp outputs. When not using the RCA Line Input connectors, you should connect these wires to the speaker output leads of your head unit. The MRV-V500 accepts input from high power or standard power head units.

#### NOTE:

- For the "Speaker Level Input System" setting, connecting the Remote Turn-On Lead is not required due to the "REMOTE SENSING" function of this product. However, the "REMOTE SENSING" function may not work depending on the signal source connected. In such a case, connect the Remote Turn-On Lead to an incoming power supply cord (accessory power) in the ACC position.

### 8 RCA Input Jacks

Connect these jacks to the line out leads on your head unit using RCA extension cables (sold separately). Be sure to observe correct channel connections; Left to Left and Right to Right.

### 9 Remote Bass Control (Optional)

Connect the Remote Bass Control Unit (sold separately) to adjust the output level remotely. This is not to replace appropriate gain level setting between the amplifier and head unit.

### 10 Speaker Input Connector

#### 11 Front Left Speaker (White (+))

#### 12 Front Left Speaker (White/Black (-))

#### 13 Front Right Speaker (Gray (+))

#### 14 Front Right Speaker (Gray/Black (-))

#### 15 Rear Right Speaker (Violet/Black (-))

#### 16 Rear Right Speaker (Violet (+))

#### 17 Rear Left Speaker (Green/Black (-))

#### 18 Rear Left Speaker (Green (+))

## CAUTION

### About Power supply wires

If the length of the power and ground cables exceed 1 m, or if you connect more than one amplifier, a distribution block should be used. See below for wire gauge recommendations for distribution block connection to battery and ground (depends upon wire length necessary): 2 AWG (33 mm<sup>2</sup>) or 1/0 AWG (53 mm<sup>2</sup>)

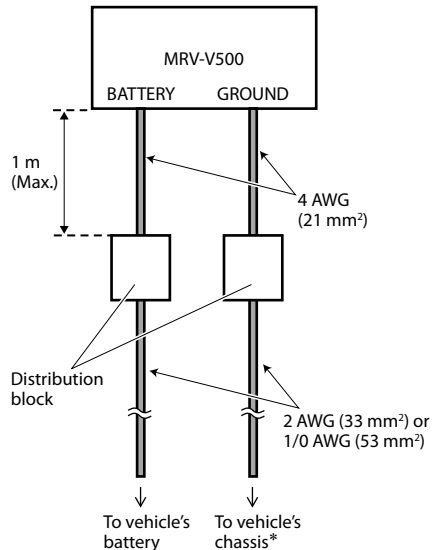

**Fig. 4**

\* Connect all equipment to the same ground point while keeping wire length as short as possible.

Ensure that you install a correctly-rated in-line fuse on the power cable near the battery positive post.

### Cautions on wire lead connections

When using third-party wire cables (power supply wire), use the supplied screws to simplify the connection. Refer to the description below for the proper procedure. If you are in doubt about how to make this connection, consult your dealer.

#### 1. Check the wire size.

- Required Wire Size
  - Battery Lead/Ground Lead....4 AWG (21 mm<sup>2</sup>)
  - Remote Turn-On Lead.....12 AWG (3 mm<sup>2</sup>)
  - Speaker Output Lead:
    - SUB W.....12 AWG (3 mm<sup>2</sup>)
    - CH-1/2/3/4 .....12 AWG (3 mm<sup>2</sup>)
- If the wire gauge used is unknown, ask your dealer.



- Remove the insulation from the ends of the wire leads by about 7 – 10 mm (9/32" – 13/32"). (Fig. 5)

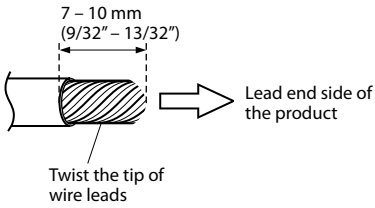
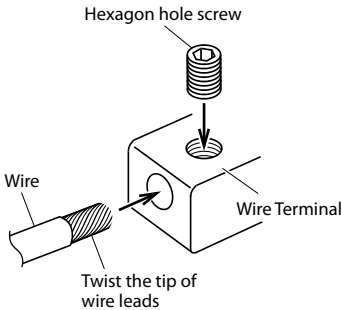

**Fig. 5**

**NOTES:**

- If length of the exposed wire is too short, a poor connection may occur causing operation failure or sound interruption.
  - On the other hand, if the length is too long, an electrical short-circuit may occur.
- Tighten the hexagon hole screw with the hexagon wrench (included) to secure the lead. (Fig. 6)

**Before making this connection, use insulated shrink tubing to cover any exposed wire extending beyond the terminal.**



**Fig. 6**

**NOTES:**

- Use only the screws included.
- For safety reasons, connect the battery leads last.
- To prevent disconnection of the leads or dropping of the unit, do not use the cabling to carry the unit.

# CONNECTION CHECK LIST

Please check your head unit for the conditions listed below: (Fig. 7)

## Remote Turn-On Lead

- The head unit does not have a remote turn-on or power antenna lead.
- The head unit's power antenna lead is activated only when the radio is on (turns off in the tape or CD Mode).
- The head unit's power antenna lead is logic level output (+) 5V, negative trigger (grounding type), or cannot sustain (+) 12V when connected to other equipment in addition to the vehicle's power antenna.

If any of the above conditions exist, the remote turn-on lead of your MRV-V500 must be connected to a switched power source (ignition) in the vehicle. Be sure to use a 3A fuse as close as possible to this ignition tap. Using this connection method, the MRV-V500 will turn on and stay on as long as the ignition switch is on.

If this is objectionable, a SPST (Single Pole, Single Throw) switch, in addition to the 3A fuse mentioned above, may be installed in-line on the MRV-V500 turn-on lead. This switch will then be used to turn on (and off) the MRV-V500. Therefore, the switch should be mounted so that is accessible by the driver. Make sure the switch is turned off when the vehicle is not running. Otherwise, the amplifier will remain on and drain the battery.

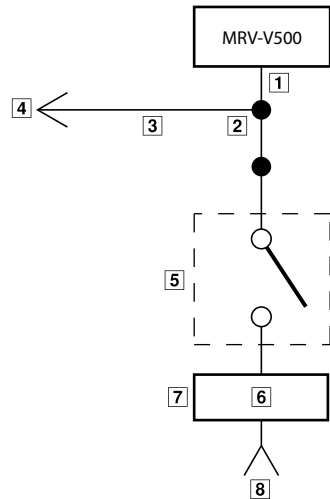

Fig. 7

- Blue/White
- Power Antenna
- Remote Turn-On Lead
- To other Alpine component's Remote Turn-On Leads
- SPST Switch (optional)
- Fuse (3A)
- As close as possible to the vehicle's ignition tap
- Ignition Source

# SWITCH SETTINGS

## NOTE:

- Before switching each Selector Switch, turn off the power and insert a small screwdriver, etc., perpendicularly to the Switch.

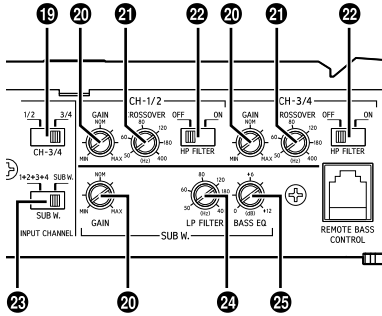

Fig. 8

## 19 Input Channel Selector Switch



- a) This switch setting is for selecting either 2-channel or 4-channel input mode. When set to "1/2", signal will be copied from CH-1/2 and sent to CH-3/4, eliminating the need for Y-adapters.



- b) Setting this switch to "3/4" will keep both inputs, CH-1/2 and CH-3/4 independent. A 4-channel source is required for this mode.

## 20 Input Gain Adjustment Control

Set the MRV-V500 input gain to the minimum position. Using a dynamic CD as a source, increase the head unit volume until the output distorts. Then, reduce the volume 1 step (or until the output is no longer distorted). Now, increase the amplifier gain until the sound from the speakers becomes distorted. Reduce the gain slightly so the sound is no longer distorted to achieve the optimum gain setting.

## 21 Crossover Frequency Adjustment Knob (LP FILTER)

Use this control to adjust the crossover frequency between 50 and 400 Hz.

## 22 Crossover Mode Selector Switch



- a) Set to the "OFF" position when the amplifier will be used for driving full range speakers or when using an external electronic crossover. The full frequency bandwidth will be output to the speakers with no high or low frequency attenuation.



- b) Set to the "ON" position when the amplifier is used to drive a tweeter/midrange system. The frequencies below the crossover point will be attenuated at 12 dB/octave.

## NOTE:

- In this case the maximum Bass EQ boost level is reduced.

## 23 Input Channel Selector Switch (SUB W.)



- a) When this switch is placed in the "1+2+3+4" position, all the signals are mixed and come out from the SUB W. This setting provides signal to the subwoofer channel when only 4 channel input is available.



- b) Setting this switch to "SUB W." will send the signal at the inputs of SUB W. (L/R) to SUB W. of the MRV-V500.

## 24 Crossover Frequency Adjustment Knob (LP FILTER)

Use this control to adjust the crossover frequency between 50 to 400 Hz.

## 25 Bass EQ Adjustment Knob

Add a 50 Hz bass boost up to +12 dB to tune your bass response.

## About Power Indicator

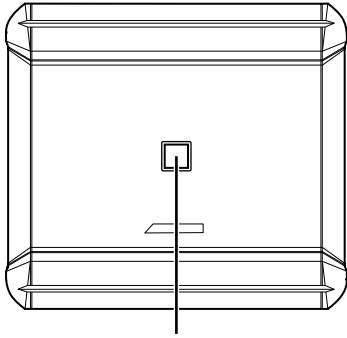

Power Indicator

**Fig. 9**

Lights up when power is on.  
Is off when power is off.

Indication color	Status	Solution
Blue	Amplifier circuit is normal.	
Red (blinking)	Operating temperature is high.	Decrease the vehicle's interior temperature to a normal level. The indicator color changes to blue.
Red	Amplifier circuit is abnormal. An electrical short has occurred, or supply current is too high.	Turn off the power supply and eliminate the cause. Then turn on the unit and verify that the indicator color has changed to blue. If it remains red, turn off the unit and consult your dealer.
	Operating temperature is too high.	Decrease the vehicle's interior temperature to a normal level. The indicator color changes to blue.
	Power supply voltage is too high.	Use the correct power supply voltage. The indicator color changes to blue.

# SYSTEM DIAGRAMS

- 26 Front Speakers
- 27 Rear Speakers
- 28 Subwoofer
- 29 Head Unit, etc.
- 30 Front Output

- 31 Rear Output
- 32 Subwoofer Output
- 33 RCA Extension Cable (Sold Separately)
- 34 Y-Adapter (Sold Separately)

## TYPICAL SYSTEM CONNECTIONS

### 4 Speaker + 1 Subwoofer System (5-Channel Input)

#### Input Channel Selector Switch Setting

CH-3/4

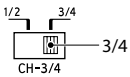

SUB W.

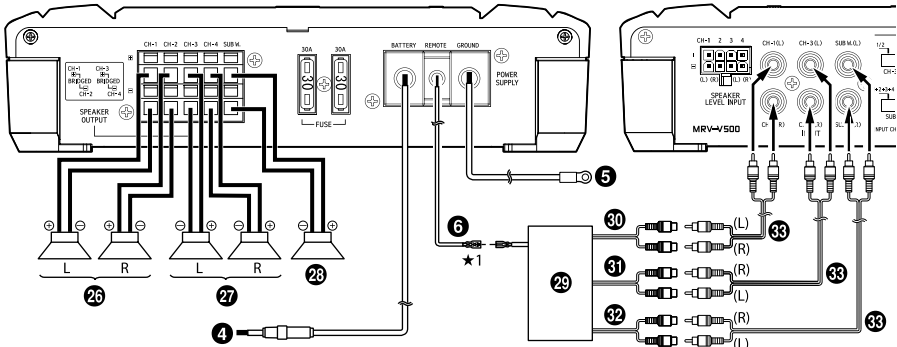
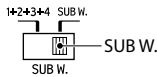

#### Connecting to the Speaker Level Input System

- ★1 For the "Speaker Level Input System" setting, connecting the Remote Turn-On Lead is not required due to the "REMOTE SENSING" function of this product. However, the "REMOTE SENSING" function may not work depending on the signal source connected. In such a case, connect the Remote Turn-On Lead to an incoming power supply cord (accessory power) in the ACC position.
- ★2 If connecting both Speaker Input Leads and RCA Inputs at the same time, do not connect both signals to the same input channel of the amplifier. Instead, be sure to connect each pair of inputs to a different Input channel pair.

example:

Speaker Input Leads:

FL/FR to CH1/CH2, RL/RR to CH3/CH4

RCA Inputs:

SUBWL/SUBWR to SUBWL/SUBWR

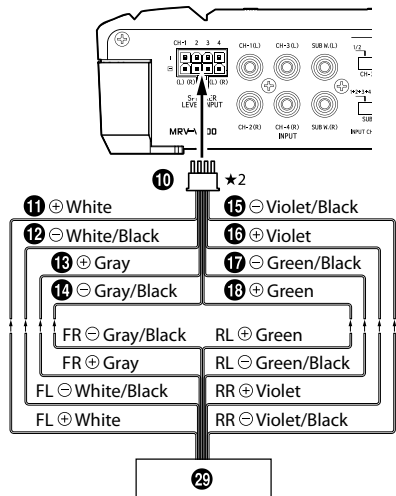

Fig. 10

## 4 Speaker + 1 Subwoofer System (4-Channel Input)

### Input Channel Selector Switch Setting

CH-3/4

SUB W.

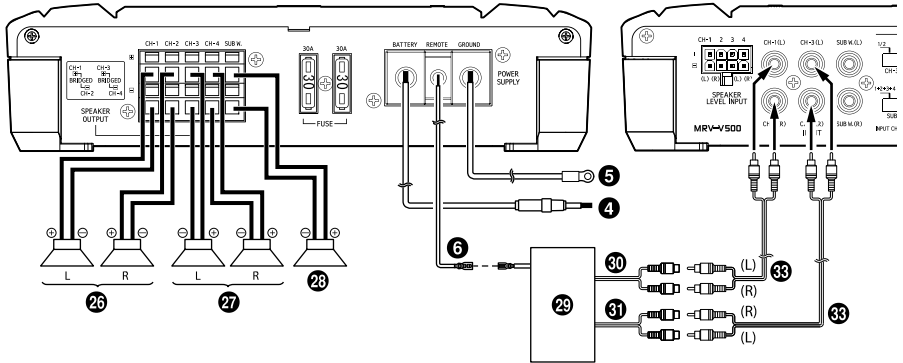
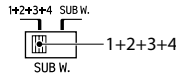
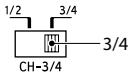

Fig. 11

## 4 Speaker + 1 Subwoofer System (2-Channel Input)

### Input Channel Selector Switch Setting

CH-3/4

SUB W.

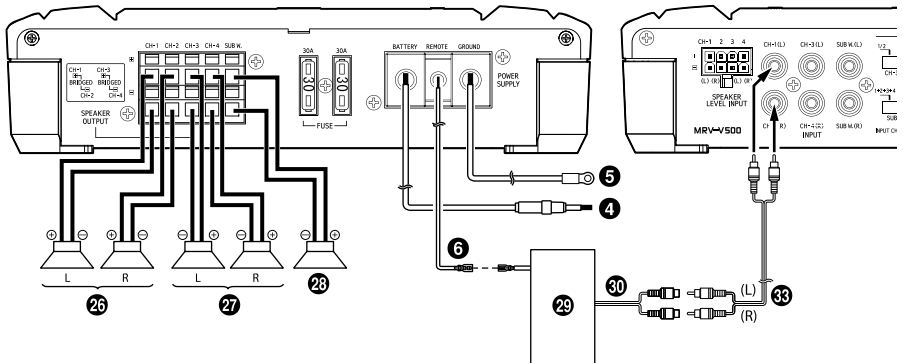
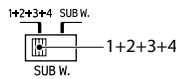
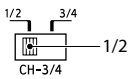

Fig. 12

# BRIDGED CONNECTIONS

## 2 Speaker + 1 Subwoofer System

### Input Channel Selector Switch Setting

CH-3/4

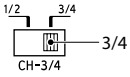

SUB W.

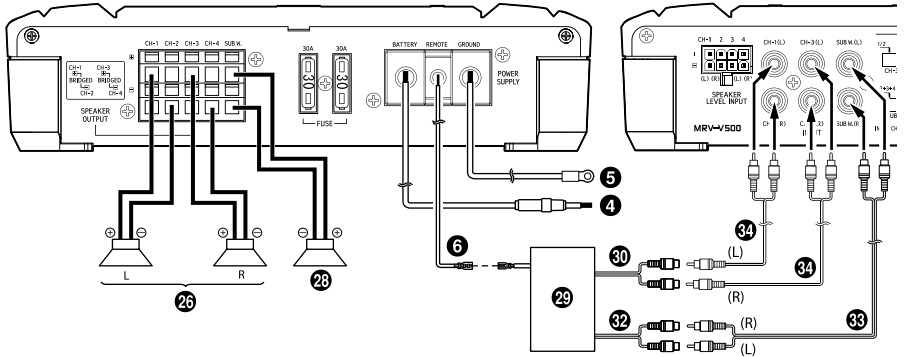
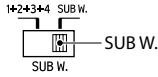

Fig. 13

## Important Tips on Bridging an Amplifier

### NOTE:

- Low output will result if only one channel input is used. The Y-adapter is not required if a stereo/mono pair line output is used to drive both inputs of the bridged amp.



Proper connection

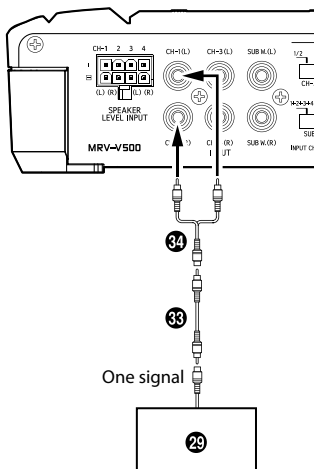

Improper connection

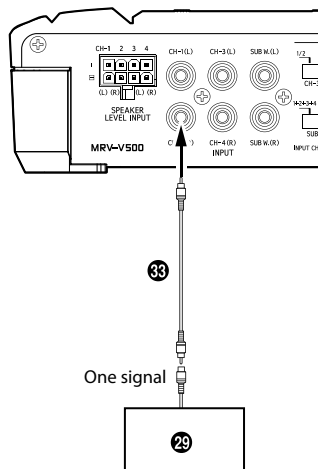

Fig. 14

# SPECIFICATIONS

		MRV-V500	
		CH-1/2/3/4	SUB W.
<b>Performance</b>			
Power Output	Per Channel, Ref.: 4 $\Omega$ , 14.4 V	40 W RMS x 4	150 W RMS x 1
	Per Channel, Ref.: 2 $\Omega$ , 14.4 V	60 W RMS x 4	250 W RMS x 1
	Bridged, Ref.: 4 $\Omega$ , 14.4 V	120 W RMS x 2	–
THD+N	Ref.: 10 W into 4 $\Omega$	$\leq 0.02\%$	$\leq 0.02\%$
	Ref.: 10 W into 2 $\Omega$	$\leq 0.03\%$	$\leq 0.03\%$
	Ref.: Rated Power into 4 $\Omega$	$\leq 0.07\%$	$\leq 0.07\%$
	Ref.: Rated Power into 2 $\Omega$	$\leq 0.09\%$	$\leq 0.09\%$
S/N Ratio	IHF A-wtd + AES-17 Ref.: 1W into 4 $\Omega$	>81 dB	>81 dB
	IHF A-wtd + AES-17 Ref.: Rated Power into 4 $\Omega$	>98 dB	>104 dB
Frequency Response	+0/-3 dB, Ref.: 1 W into 4 $\Omega$	10 Hz - 45 kHz	10 Hz - 400 Hz
	+0/-1 dB, Ref.: 1 W into 4 $\Omega$	20 Hz - 20 kHz	20 Hz - 300 Hz
Damping Factor	Ref.: 10 W into 4 $\Omega$ at 100 Hz	>90	>500
<b>Control</b>			
Input Select	Selectable Input Signal Configuration (2ch/4ch/6ch Input)	CH-3/4: CH-1/2 or CH-3/4	CH-1+2+3+4 or SUB W.
Input Sensitivity	RCA Input Ref.: Rated Power into 4 $\Omega$	0.2 - 4.0 V	0.2 - 4.0 V
Crossover	Variable HPF/LPF	HPF: 50 Hz - 400 Hz (-12 dB/oct.)	LPF: 50 Hz - 400 Hz (-24 dB/oct.)
Equalizer	Bass EQ ( $f_c=50$ Hz)	–	0 to +12 dB (Variable)
Remote Level*	Linear Attenuation * Requires optional RUX-KNOB	–	0 to -20 dB
<b>General</b>			
Input Impedance		>10 k $\Omega$	
Dimensions	Width	244.5 mm (9-3/4")	
	Height	55 mm (2-1/4")	
	Depth	219 mm (8-5/8")	
Weight		2.57 kg (5 lb 11 oz)	

## NOTE:

- Specifications and design are subject to change without notice.